



**XOD12HPBF**  
SINK PRO NANOGRIND

## QUICKONNECT BATCH FEED WASTE DISPOSALS



**XOD12HPBF**

- QuicKconnect Twist-Lock Mount
- High Speed Magnet Motor
- Septic Safe

### YOUR XO KITCHEN WASTE DISPOSAL

XO WASTE DISPOSALS are the green kitchen convenience you can feel good about buying and using. Make cleanups a breeze and your kitchen clean and odor free. Quick, quiet grinding power to cut through tough foods. Backed by the best warranty in the business. Strong, Quiet, Reliable and takes out the garbage without being asked twice.

Is it possible to fall in love with an appliance?

WORLD CLASS SERVICE | COMPREHENSIVE WARRANTIES

OUR LASTING COMMITMENT TO YOU

CATEGORY: Batch Feed **QuickConnect Mount System**

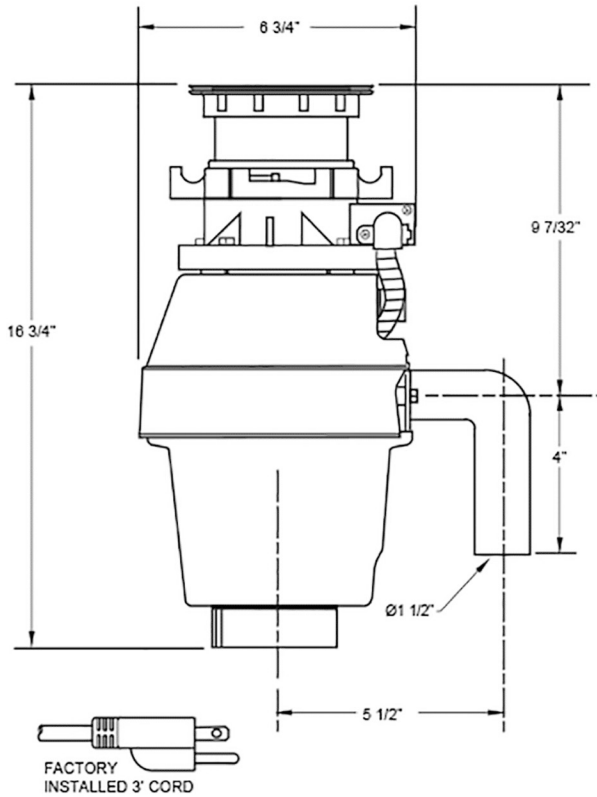

**NOTE: Flange Fits 3-1/2" Kitchen Sink Openings**



### PRODUCT HIGHLIGHTS

- Permanent Magnet Motor
- Generates High Torque / Avoid Jams
- Stainless Steel Turntable & Cast Impellers
- Bio-guard Antimicrobial Protection
- Safety Feed Stopper
- Factory Installed Power Cord and Plug
- Precision Balanced
- Septic Safe / Fine Grind
- XO QuickConnect Mount

### SPECIFICATIONS

- 1/2 HP Batch Feed Disposal
- 3' Long 3 Prong Power Cord
- Manual Reset Thermal Overload Protection
- 120 V / 60 Hz - 3.1 amps
- All XO Disposals are UL Listed

#### **SAFETY FEED GUARD**

No remote switch required. Unit operates when the Safety Feed Guard is inserted into the drain and pushed down to activate

