

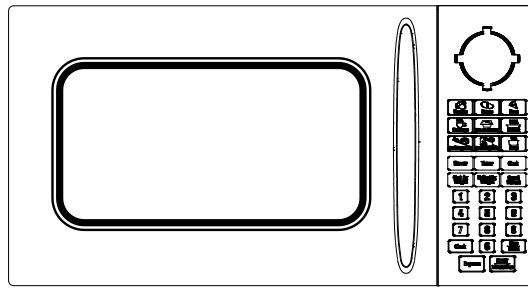

Microwave Oven

Model SM1102WH



User's manual

Please read these instructions carefully before installing and operating the oven.

Record in the space below the SERIAL NO. found on the nameplate on your oven and retain this information for future reference.

SERIAL NO. _____

Please save sales receipt for warranty.

Felix Storch, Inc.
Summit Appliance Division
An ISO 9001:2008 registered company
770 Garrison Avenue
Bronx, New York 10474
www.summitappliance.com

PRECAUTIONS TO AVOID POSSIBLE EXPOSURE TO EXCESSIVE MICROWAVE ENERGY

- Do not attempt to operate this oven with the door open since open-door operation can result in harmful exposure to microwave energy. It is important not to defeat or tamper with the safety interlocks.
- Do not place any object between the oven front face and the door or allow soil or cleaner residue to accumulate on sealing surfaces.
- Do not operate the oven if it is damaged. It is particularly important that the oven door close properly and that there is no damage to the:
 - a. Door (bent),
 - b. Hinges and latches (broken or loosened),
 - c. Door seals and sealing surfaces.
- The oven should not be adjusted or repaired by anyone except properly qualified service personnel.

CONTENTS

<i>Precautions to Avoid Possible Exposure to Excessive Microwave Energy</i>	1
<i>Important Safety Instructions</i>	2
<i>Installation Guide</i>	4
<i>Grounding Instructions</i>	4
<i>Utensils Guide</i>	5
<i>Cooking Techniques</i>	6
<i>Before You Call for Service</i>	6
<i>Specifications</i>	7
<i>Location of Parts</i>	7
<i>Control Panel</i>	8
<i>Operating Instructions</i>	9
<i>Setting the clock</i>	9
<i>Setting the timer</i>	9
<i>Microwave cooking</i>	9
<i>Speed defrost</i>	9
<i>Cook by weight</i>	9
<i>Defrost by weight</i>	10
<i>Multistage cooking</i>	10
<i>Minute Plus</i>	10
<i>Express</i>	11
<i>Setting child lock</i>	11
<i>Quick Cook Settings</i>	11
<i>Popcorn</i>	11
<i>Potato</i>	11
<i>Pizza</i>	11
<i>Beverage</i>	11
<i>Frozen Dinner</i>	12
<i>Fresh Vegetable</i>	12
<i>Frozen Vegetable</i>	12
<i>Soup</i>	12
<i>Reheat</i>	12
<i>Care and Cleaning</i>	13
<i>Limited Warranty</i>	14

IMPORTANT SAFETY INSTRUCTIONS

When using electrical appliances, basic safety precautions should be followed, including the following:

WARNING - To reduce the risk of burns, electric shock, fire, injury to persons or exposure to excessive microwave energy:

- Read all instructions before using the appliance.
- Read and follow the specific "PRECAUTIONS TO AVOID POSSIBLE EXPOSURE TO EXCESSIVE MICROWAVE ENERGY" on page 1.
- This appliance must be grounded. Connect only to a properly grounded outlet. See "GROUNDING INSTRUCTIONS" on page 4.
- Install or locate this appliance only in accordance with the provided installation instructions.
- Some products such as whole eggs and sealed containers (for example, closed glass jars) can explode and should not be heated in this oven.
- Use this appliance only for its intended use as described in this manual. Do not use corrosive chemicals or vapors in this appliance. This type of oven is specifically designed to heat, cook or dry food. It is not designed for industrial or laboratory use.
- As with any appliance, close supervision is necessary when used by children.
- To reduce the risk of fire in the oven cavity:
 - a. Do not overcook food. Carefully attend appliance when paper, plastic, or other combustible materials are placed inside the oven to facilitate cooking.
 - b. Remove wire twist-ties from bags before placing bags in oven.
 - c. If materials inside the oven should ignite, keep oven door closed, turn oven off, and disconnect the power cord or shut off power at the fuse or circuit breaker panel.
 - d. Do not use the cavity for storage purposes. Do not leave paper products, cooking utensils or food in the cavity when not in use.
- Liquids such as water, coffee, or tea can be overheated beyond the boiling point without appearing to be boiling due to surface tension of the liquid. Visible bubbling or boiling when the container is removed from the microwave oven is not always present. **THIS COULD RESULT IN VERY HOT LIQUIDS SUDDENLY BOILING OVER WHEN A SPOON OR OTHER UTENSIL IS INSERTED INTO THE LIQUID.** To reduce the risk of injury to persons:
 - a. Do not overheat the liquid.
 - b. Stir the liquid both before and halfway through heating it.
 - c. Do not use straight-sided containers with narrow necks.
 - d. After heating, allow the container to stand in the microwave oven for a short time before removing the container.
 - e. Use extreme care when inserting a spoon or other utensil into the container.
- Do not heat oil or fat for deep-frying. It is difficult to control the temperature of oil in a microwave oven.
- Pierce foods with skins such as potatoes, whole squash, apples and chestnuts before cooking.
- The contents of feeding bottles and baby jars should be stirred or shaken and the temperature should be checked before serving in order to avoid burns.
- Cooking utensils may become hot because of heat transferred from the heated food. Potholders may be needed to handle the utensil.
- Do not cover or block any openings on the appliance.
- Do not store or use this appliance outdoors. Do not use this product near water, for example, near a kitchen sink, in a wet basement, near a swimming pool, or similar locations.
- Do not operate this appliance if it has a damaged cord or a plug, if it is not working properly or if it has been damaged or dropped.
- Do not immerse cord or plug in water. Keep cord away from heated surface. Do not let cord hang over edge of table or counter.

- Use only thermometers which are specifically designed for use in microwave ovens.
- Do not operate any heating or cooking appliance below this appliance.
- Be certain the glass tray and roller rings are in place when you operate the oven.
- This appliance should be serviced only by

qualified service personnel. Contact nearest authorized service facility for examination, repair or adjustment.

- When cleaning surfaces of door and oven that come together on closing the door, use only mild, nonabrasive soaps, or detergents applied with a sponge or soft cloth.

SAVE THESE INSTRUCTIONS

INSTALLATION GUIDE

- Make sure that all the packing materials are removed from the inside of the door.
- Check the oven for any damage, such as misaligned or bent door, damaged door seals and sealing surface, broken or loose door hinges and latches and dents inside the cavity or on the door. If there is any damage, do not operate the oven but contact qualified service personnel.
- This microwave oven must be placed on a flat, stable surface to hold its weight and the heaviest food likely to be cooked in the oven.
- Do not place the oven where heat, moisture, or high humidity are generated, or near combustible materials.

- For correct operation, the oven must have sufficient airflow. Allow 20cm of space above the oven, 10cm at back and 5cm at both sides. Do not cover or block any openings on the appliance. Do not remove feet on which oven stands.
- Do not operate the oven without glass tray, roller support, and shaft in their proper positions.
- Make sure that the power supply cord is undamaged and does not run under the oven or over any hot or sharp surface.
- The socket must be readily accessible so that it can be easily unplugged in an emergency.

GROUNDING INSTRUCTIONS

This appliance must be grounded. In the event of an electrical short circuit, grounding reduces the risk of electric shock by providing an escape wire for the electric current.

WARNING: Improper use of the grounding plug can result in a risk of electric shock.

Consult a qualified electrician or service technician if the grounding instructions are not completely understood, or if doubt exists as to whether the appliance is properly grounded, or if an extension cord may be used.

1) If it is necessary to use an extension cord: Use only a 3-wire extension cord that has a 3-blade grounding plug and a 3-slot receptacle that will accept the plug on the appliance. The marked rating of the extension cord shall be equal to or greater than the electrical rating of the appliance, or 2) If an extension cord should not be used: Have a qualified electrician or service technician install an outlet near the appliance if the power supply cord is too short.

Electrical Requirements

The electrical requirements are: 120 volt 60 Hz, AC only, 20 amp. It is recommended that a separate circuit serving only the oven be provided. The oven is equipped with a 3-prong grounding plug. It must be plugged into a wall receptacle that is properly installed and grounded.

Power Supply Cord

1. A short power supply cord is provided to reduce the risks resulting from becoming entangled in or tripping over a longer cord.
2. Longer cord sets or extension cords are available and may be used if care is exercised in their use.
3. If long cord or extension cord is used:
 - The marked electrical rating of the cord set or extension cord should be at least as great as the electrical rating of the appliance.

- The extension cord must be a grounding-type 3-wire cord, and the longer cord should be arranged so that it will not drape over the counter top or table top where it can be pulled on by children or tripped over unintentionally.

Notes:

If you have any questions about the grounding or electrical instructions, consult a qualified electrician or service person.

Neither the manufacturer nor the dealer can

accept any liability for damage to the oven or personal injury resulting from failure to observe the electrical connection procedures.

Radio or TV Interference

Should there be any interference caused by the microwave oven to your radio or TV, check that the microwave oven is on a different circuit, relocate the radio or TV as far away from the oven as feasible or check position and signal of receiving antenna.

UTENSILS GUIDE

This section lists which utensils can be used in the microwave, which ones have limited use for short periods, and which ones should not be used in the microwave.

 **RECOMMENDED**

Microwave browning dish — Use to brown the exterior of small items such as steaks, chops, or pancakes. Follow the directions provided with your browning dish.

Microwaveable plastic wrap — Use to retain steam. Leave a small opening for some steam to escape and avoid placing it directly on the food.

Paper towels and napkins — Use for short-term heating and covering; these absorb excess moisture and prevent spattering. Do not use recycled paper towels, which may contain metal and could ignite.

Glass and glass-ceramic bowls and dishes — Use for heating or cooking.

Paper plates and cups — Use for short-term heating at low temperatures. Do not use recycled paper, which may contain metal and could ignite.

Wax paper — Use as a cover to prevent spattering.

Thermometers — Use only those labeled "Microwave Safe" and follow all directions. Check the food in several places. Conventional

thermometers may be used on microwaved food once the food has been removed from the oven.

 **LIMITED USE**

Aluminum foil — Use narrow strips of foil to prevent overcooking of exposed areas. Using too much foil can damage your oven, so be careful. You should keep a distance of 1 inch (2.54cm) between aluminum foil and cavity.

Ceramic, porcelain, and stoneware— Use these if they are labeled "Microwave Safe". If they are not labeled, test them to make sure they can be used safely.

Plastic — Use only if labeled "Microwave Safe". Other plastics can melt.

 **Not Recommended**

Glass jars and bottles — Regular glass is too thin to be used in a microwave. It can shatter and cause damage and injury.

Paper bags — These are a fire hazard, except for popcorn bags that are designed for microwave use.

Styrofoam plates and cups — These can melt and leave an unhealthy residue on food.

Plastic storage and food containers — Containers such as margarine tubs can melt in the microwave.

Metal utensils — These can damage your oven. Remove all metal before cooking.

Note:

Should you wish to check if a dish is safe for microwaving, place the empty dish in the oven

and microwave on HIGH for 30 seconds. A dish which becomes very hot should not be used.

COOKING TECHNIQUES

Your microwave makes cooking easier than conventional cooking, provided you keep these considerations in mind:

STIRRING

Stir foods such as casseroles and vegetables while cooking to distribute heat evenly. Food at the outside of the dish absorbs more energy and heats more quickly, so stir from the outside to the center. The oven will turn off when you open the door to stir your food.

ARRANGEMENT

Arrange unevenly shaped foods, such as chicken pieces or chops, with the thicker, meatier parts toward the outside of the turntable where they receive more microwave energy. To prevent overcooking, place delicate foods, such as asparagus tips, toward the center of the turntable.

SHIELDING

Shield food with narrow strips of aluminum foil to prevent overcooking. Areas that need shielding include poultry wing tips, the ends of poultry legs, and corners of square baking dishes. Use only small amounts of aluminum foil. Larger amounts can damage your oven.

TURNING

Turn foods over midway through cooking to expose all parts to microwave energy. This is especially important with large foods such as roasts.

STANDING

Foods cooked in the microwave build up internal heat and continue to cook for a few minutes after heating stops. Let foods stand to complete cooking, especially foods such as cakes and whole vegetables. Roasts need this time to complete cooking in the center without overcooking the outer areas. All liquids, such as soup or hot chocolate, should be shaken or stirred when cooking is complete. Let liquids stand a moment before serving. When heating baby food, stir well at removal and test the temperature before serving.

ADDING MOISTURE

Microwave energy is attracted to water molecules. Food that is uneven in moisture content should be covered or allowed to stand so that the heat disperses evenly. Add a small amount of water to dry food to help it cook.

BEFORE YOU CALL FOR SERVICE

IF THE OVEN FAILS TO OPERATE

1. Check to ensure that the oven is plugged in securely. If it is not, remove the plug from the outlet, wait 10 seconds, and plug it in again securely.
2. Check for a blown circuit fuse or a tripped main circuit breaker. If these seem to be operating properly, test the outlet with another appliance.
3. Check to ensure that the control panel is programmed correctly and the timer is set.

4. Check to ensure that the door is securely engaged. Otherwise, the oven will not operate. Otherwise, the oven will not operate.

IF NONE OF THE ABOVE RECTIFIES THE SITUATION, THEN CONTACT A QUALIFIED TECHNICIAN. DO NOT TRY TO ADJUST OR REPAIR THE OVEN YOURSELF.

SPECIFICATIONS

Power Consumption:	120V~60Hz, 1450W (microwave)
Output:	1000W
Operation Frequency:	2450MHz
Outside Dimensions (H×W×D):	11¹³/₁₆ × 21¹/₄ × 17⁵/₁₆ inches
Oven Cavity Dimensions (H×W×D):	8¹¹/₁₆ × 13¹⁵/₁₆ × 14¹/₈ inches
Oven Capacity:	1.0 cu. ft.
Cooking Uniformity:	Turtable System
Net Weight:	Approx. 35.3 lb.

LOCATION OF PARTS

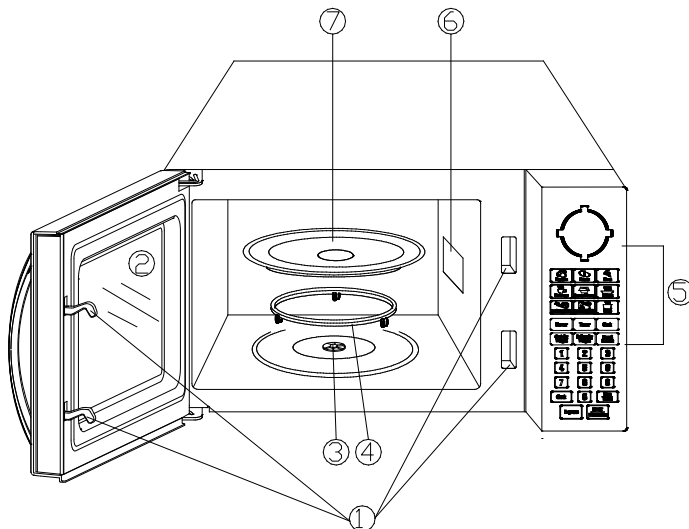

1. Door Safety Lock System
2. Oven Window
3. Shaft
4. Turntable Roller
5. Control Panel
6. Wave Guide
(Please do not remove the mica plate covering the wave guide)
7. Glass Tray

CONTROL PANEL

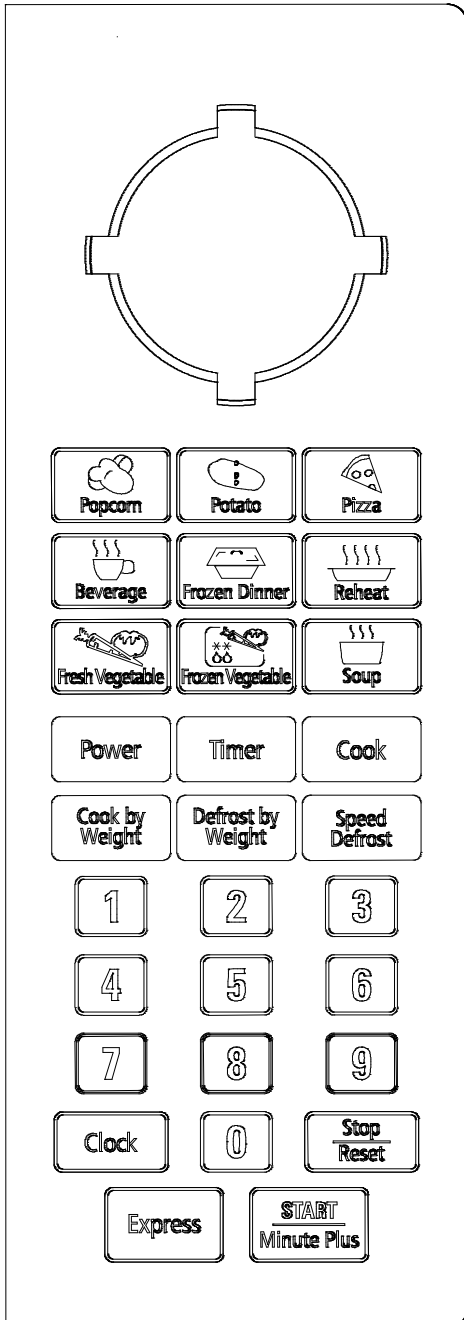

- **MENU ACTION SCREEN**

Cooking time, power, indicators and present time are displayed.

- **QUICK COOK BUTTONS**

Instant settings to cook popular foods.

- **POWER**

Use to set power levels other than high.

- **TIMER**

Timer functions independently, even while a cooking program is in process.

- **COOK**

Use for multi-stage cooking. It enables cooking at multiple power and time settings automatically.

- **COOK BY WEIGHT**

Programmed cooking based on weight of foods cooked.

- **DEFROST BY WEIGHT**

Programmed defrosting based on the weight of the foods to be defrosted.

- **SPEED DEFROST**

Quick defrost function that alternates defrost and times to quickly and effectively defrost foods.

- **NUMBER PADS (0-9)**

Touch to set time or food weight.

- **CLOCK**

Touch to set clock time.

- **STOP/RESET**

Press to cancel setting or reset the oven before setting a cooking program.

Press once to temporarily stop cooking, or twice to cancel cooking altogether.

It is also used for setting child lock.

- **EXPRESS**

Use this feature to program the oven to microwave food at 100% power conveniently.

- **START/MINUTE PLUS**

Touch to start cooking or to add an extra minute to your cooking cycle for each touch.

OPERATION INSTRUCTIONS

SIGNALS DURING OVEN SETTINGS

ONE SIGNAL: Oven accepts the entry.

TWO SIGNALS: Oven does not accept the entry, please check and try again.

SETTING THE CLOCK

1. Touch CLOCK pad once or twice.
2. Use the number pads to enter the correct time.
3. Touch CLOCK pad again.

NOTE:

This is a 12- or 24-hour clock. You can press CLOCK pad to choose. During cooking, you can press the CLOCK to check the clock time.

SETTING THE TIMER

1. Touch TIMER.
2. Enter the amount of time by touching the number pads.
3. Touch START/MINUTE PLUS.

NOTE:

- The longest time to be counted down is 99 minutes and 99 seconds.
- Time countdown can be seen in display for 3 seconds before clock or cooking time is returned to display.
- Touch TIMER and then touch STOP/RESET to cancel TIMER during timing process.

MICROWAVE COOKING

For microwave cooking, the longest cooking time is 99 minutes and 99 seconds.

Select power level by pressing POWER button:

Press POWER button	Power
once	100%
twice	80%
3 times	60%
4 times	40%
5 times	20%
6 times	0

For example, suppose you want to cook for 1 minute at 60% of microwave power.

1. Press POWER to enter power level.
2. Use number pads to enter cooking time.
3. Touch START/MINUTE PLUS.

NOTE:

- If you want to set 100% power level, you can omit the first step given above.
- During cooking process, you can check current cooking power by pressing POWER, or to extend cooking time by pressing START/MINUTE PLUS, each press adds 1 minute.

SPEED DEFROST

The longest defrosting time is 99 min and 99 sec.

1. Touch SPEED DEFROST.
2. Enter desired defrosting time by touching correct number pads.
3. Touch START/MINUTE PLUS.

NOTE:

Turn over food when oven pauses and signals. Touch START/MINUTE PLUS to resume defrosting.

COOK BY WEIGHT

The oven can be used to cook based on the weight you enter.

STEPS:

1. Touch COOK BY WEIGHT to select the one digit code.
2. Use the number pad to enter food weight (lb digit: from 1lb to 5 lb).
3. Touch COOK BY WEIGHT again.
4. Use the number pad to enter food weight (oz digit: from 1 oz to 16 oz).
5. Touch START/MINUTE PLUS.

Cook By Weight Code Description

CODE	TYPE	MAX WEIGHT
d1	Beef	5 lb. 4 oz.
d2	Mutton	5 lb. 4 oz.
d3	Pork	5 lb. 4 oz.

NOTE:

- Meat must be defrosted at refrigerator temperature.
- Weight must be in pounds and ounces.
- Ounce weights less than 10 must be preceded by a 0. If label gives weight in pounds only, change the fraction of a pound to ounces by using the following chart.

Converting Fractions of a Pound to Ounces

Fractions of a pound	Ounces
Less than .03	0
.03 to .09	1
.10 to .15	2
.16 to .21	3
.22 to .27	4
.28 to .34	5
.35 to .40	6
.41 to .46	7
.47 to .53	8
.54 to .59	9
.60 to .65	10
.66 to .71	11
.72 to .78	12
.79 to .84	13
.85 to .90	14
.91 to .97	15
above .97	go to next whole #

- Turn over meat when oven pauses and signals. Touch START/MINUTE PLUS to resume cooking.
- Leave the meat a few minutes before carving.

DEFROST BY WEIGHT

1. Touch DEFROST BY WEIGHT once, "0.00", "LB" and "❄️" shows on display.

2. Use the number pad 1-5 to enter food weight (lb digit: from 1lb to 5 lb).
3. Touch DEFROST BY WEIGHT again.
4. Use the number pad to enter food weight (oz digit: from 1 oz to 16 oz).
5. Touch START/MINUTE PLUS.

NOTE:

- Weight must be in pounds and ounces. Ounce weights less than 10 must be preceded by a 0. If label gives weight in pounds only, change the fraction of a pound to ounces by using the chart given above. Maximum weight is 5 lb 4oz.
- Turn over food when oven pauses and signals. Touch START/MINUTE PLUS to resume defrosting.

MULTISTAGE COOKING

Your oven can be programmed for up to 3 automatic cooking sequences.

Suppose you want to set the following cooking program.

Microwave-cooking



Microwave-cooking (with lower power level)

1. Enter a stage of microwave cooking program.
2. Press COOK pad.
3. Enter another stage of microwave cooking program.
4. Press START/MINUTE PLUS.

NOTE: Speed Defrost and Defrost by Weight can only set in the first stage. Cook by Weight and Auto Cook can not be set in Multistage cooking mode.

MINUTE PLUS

Minute Plus lets you add an extra minute to the current cooking cycle at the current cooking program. You can also use it to extend cooking time in multiples of one minute.

NOTE:

To extend cooking time in multiples of one minute, touch START/MINUTE PLUS repeatedly during cooking.

You can use Minute Plus during Microwave cooking process.

EXPRESS

Express cooking helps you to cook food at 100% power level easily. Press EXPRESS pad to set cooking time, the oven will cook automatically. You can set the cooking time from 30 seconds to 10 minutes and you can also press the pad during cooking to add cooking time.

SETTING CHILD LOCK

The child lock prevents unsupervised operation by children.

To set, in standby mode, press and hold STOP/RESET for 3 seconds.  is indicated on the display.

To cancel, press and hold STOP/RESET for 3 seconds.  indication disappears.

QUICK COOK SETTINGS

The QUICK COOK settings allow you to cook or reheat food automatically without entering power level or time.

For smaller portions, simply touch the applicable pad and start. For larger portions, push the pad twice.

FROZEN DINNER, BAKED POTATO and BEVERAGE allow you to cook multiple amounts of the same food. Simply touch pad once, and ENTER AMT appears in the display. Enter the amount of servings and start.

POPCORN

1. Touch POPCORN.

POPCORN automatically sets the cooking time for a 3.5 oz. bag of microwave popcorn.

2. Touch START/MINUTE PLUS.

NOTE:

To change the preset POPCORN time: Touch POPCORN twice. Touch number pads to enter minutes and seconds. Touch START/MINUTE PLUS. The maximum time you can set is 99 minutes and 99 seconds. This new cooking time will be set as the default until you reset it or next power on.

POTATO

For small potatoes (3.5~5oz/share):

1. Touch POTATO once.

2. Enter number of potatoes by touching number pads from 1 to 4.

3. Touch START/MINUTE PLUS.

For larger potatoes (6~8 oz/share):

1. Touch POTATO twice.

2. Enter number of potatoes by touching number pads from 1 to 4.

3. Touch START/MINUTE PLUS.

PIZZA

Reheating a slice of pizza (5oz):

1. Touch PIZZA once. CODE and cooking time appear.

2. Touch START/MINUTE PLUS.

Heating a whole frozen pizza (16oz):

1. Touch PIZZA twice. CODE and cooking time appear.

2. Touch START/MINUTE PLUS.

BEVERAGE

For small cups (5~7 oz/cup):

1. Touch BEVERAGE once.

2. Enter number of cups by touching number pads from 1 to 4.

3. Touch START/MINUTE PLUS.

For larger cups (9~11 oz /cup):

1. Touch BEVERAGE twice.

2. Enter number of mugs by touching number pads from 1 to 4.
3. Touch START/MINUTE PLUS.

FROZEN DINNER

For small frozen dinners (7~9oz/share):

1. Touch FROZEN DINNER once.
2. For 1 entree, touch the number pad "1". For 2 entrees, touch the number pad "2".
3. Touch START/MINUTE PLUS pad.

For larger frozen dinners (10~12oz/share):

1. Touch FROZEN DINNER twice.
2. For 1 entree, touch the number pad "1". For 2 entrees, touch the number pad "2".
3. Touch START/MINUTE PLUS.

FRESH VEGETABLE

For vegetable weighing 5 to 9 oz per share:

1. Touch FRESH VEGETABLE once.
2. Enter number of servings by touching number pads from 1 to 6.
3. Touch START/MINUTE PLUS.

FROZEN VEGETABLE

For frozen vegetables weighing 5 to 9 oz per share:

1. Touch FROZEN VEGETABLE once.
2. Enter number of servings by touching number pads from 1 to 6.
3. Touch START/MINUTE PLUS.

SOUP

To prepare soup (7~9 oz/share):

1. Touch SOUP once.
2. Enter number of servings by touching number pads from 1 to 4.
3. Touch START/MINUTE PLUS.

REHEAT

For a plate of cool food.

1. Touch REHEAT pad. CODE and cooking time appears.
2. Touch START/MINUTE PLUS.

CARE AND CLEANING

1. Turn off the oven and remove the power plug from the wall socket before cleaning.
2. Keep the inside of the oven clean. When food splatters or spilled liquids adhere to oven walls, wipe with a damp cloth. Mild detergent may be used if the oven gets very dirty. Avoid the use of spray and other harsh cleaners as they may stain, streak or dull the door surface.
3. The outside surfaces should be cleaned with a damp cloth. To prevent damage to the operating parts inside the oven, water should not be allowed to seep into the ventilation openings.
4. Wipe the window on both sides with a damp cloth to remove any spills or splatters.
5. Do not allow the control panel to become wet. Clean with a soft, damp cloth. When cleaning the control panel, leave oven door open to prevent oven from accidentally turning on.
6. If steam accumulates inside or around the outside of the oven door, wipe with a soft cloth. This may occur when the microwave oven is operated under high humidity conditions. In such case, it is normal.
7. It is occasionally necessary to remove the glass tray for cleaning. Wash the tray in warm sudsy water or in a dishwasher.
8. The roller ring and oven floor should be cleaned regularly to avoid excessive noise. Simply wipe the bottom surface of the oven with mild detergent. The roller ring may be washed in mild sudsy water or dishwasher. After removing the roller ring from cavity floor for cleaning, be sure to replace it in the proper position.
9. Remove odors from your oven by combining a cup of water with the juice and skin of one lemon in a deep microwaveable bowl, microwave for 5 minutes. Wipe thoroughly and dry with a soft cloth.
10. When it becomes necessary to replace the oven light, please consult a dealer to have it replaced.
11. The oven should be cleaned regularly and any food deposits removed. Failure to maintain the oven in a clean condition could lead to deterioration of the surface that could adversely affect the life of the appliance and possibly result in a hazardous situation.
12. Please do not dispose of this appliance in a domestic trash bin. It should be taken to the particular disposal center provided by your municipality.

LIMITED WARRANTY

90-DAY LIMITED WARRANTY

Within the 48 contiguous United States, for 90 days from the date of purchase, when this appliance is operated and maintained according to instructions attached to or furnished with the product, warrantor will pay for factory-specified parts and repair labor to correct defects in materials or workmanship. Service must be provided by a designated service company. Outside the 48 states, all parts are warranted for 90 days from manufacturing defects. Plastic parts, shelves and cabinets are warranted to be manufactured to commercially acceptable standards, and are not covered from damage during handling or breakage.

ITEMS WARRANTOR WILL NOT PAY FOR:

1. Service calls to correct the installation of your appliance, to instruct you how to use your appliance, to replace or repair fuses or to correct wiring or plumbing.
2. Service calls to repair or replace appliance light bulbs or broken shelves. Consumable parts (such as filters) are excluded from warranty coverage.
3. Damage resulting from accident, alteration, misuse, abuse, fire, flood, acts of God, improper installation, installation not in accordance with electrical or plumbing codes, or use of products not approved by warrantor.
4. Replacement parts or repair labor costs for units operated outside the United States.
5. Repairs to parts or systems resulting from unauthorized modifications made to the appliance.
6. The removal and reinstallation of your appliance if it is installed in an inaccessible location or is not installed in accordance with published installation instructions.

DISCLAIMER OF IMPLIED WARRANTIES; LIMITATION OF REMEDIES

CUSTOMER'S SOLE AND EXCLUSIVE REMEDY UNDER THIS LIMITED WARRANTY SHALL BE PRODUCT REPAIR AS PROVIDED HEREIN. IMPLIED WARRANTIES, INCLUDING WARRANTIES OF MERCHANTABILITY OR FITNESS FOR A PARTICULAR PURPOSE, ARE LIMITED TO 90 DAYS. WARRANTOR SHALL NOT BE LIABLE FOR INCIDENTAL OR CONSEQUENTIAL DAMAGES. SOME STATES DO NOT ALLOW THE EXCLUSION OR LIMITATION OF INCIDENTAL OR CONSEQUENTIAL DAMAGES, OR LIMITATIONS ON THE DURATION OF IMPLIED WARRANTIES OF MERCHANTABILITY OR FITNESS, SO THESE EXCLUSIONS OR LIMITATIONS MAY NOT APPLY TO YOU. THIS WARRANTY GIVES YOU SPECIFIC LEGAL RIGHTS AND YOU MAY ALSO HAVE OTHER RIGHTS, WHICH VARY FROM STATE TO STATE.

WARNING! This product may contain chemicals known to the state of California to cause cancer or birth defects or other reproductive harm. For more information, visit: www.summitappliance.com/prop65

Chemicals known by the manufacturer to be present in this product in concentrations higher than threshold limits: NONE.

FELIX STORCH, INC.
770 Garrison Avenue
Bronx, NY 10474
Phone: (718) 893-3900
Fax: (844) 478-8799
www.summitappliance.com



For parts and accessory ordering,
troubleshooting and helpful hints, visit:
www.summitappliance.com/support

Printed in China