



RVB 497 790

Fully integrated panel ready
Cutout width 35 1/2" (90 cm)
Cooling section with one door and
one fully extendable freezing drawer

Included accessories

- 1 egg holder with lid
- 1 ice cube scoop
- 2 oak wood bottle holder
- 1 supply hose, 70 3/8" (1.8 m) with 1/4" male compression fitting (standard icemaker connector)

Installation accessories

RVA 421 920

Dark stainless steel door panels, with handles. For RVB 497
Panel thickness 3/4".

RVA 428 920

Dark stainless steel door panels, handleless. For RVB 497
Panel thickness 3/4".

RVA 423 141

Side trims used to conceal the gap between the appliance and adjacent cabinet.

2 pieces, for RVB and RVY.

RA 425 110

Accessory stainless steel handle for custom panel refrigerator door for RVY 497, with 3 mounts, length 44 1/2" (1.131 mm).

Order quantity 2x required.

RA 425 910

Accessory stainless steel handle for custom panel RVY 497 freezer door, with 2 mounts, length 31 3/8" (810 mm).

RVA 460 000

Accessory for side-by-side installation for RVB 497.

RVA 460 900

Accessory for replacement side-by-side installation in unmodified cutout. Required if a RVY 497 (35 1/2" wide) is installed side-by-side into a cutout which was formerly housing a combination including a RY 492, RB 492 or RC 492.

RVA 460 910

Accessory for replacement in single unmodified cutout. Required if a RVY 497 is replacing a RY 492, RB 492 or RC 492.

Fridge-freezer combination dark brushed stainless steel

RVB 497

- Dark brushed stainless steel interior, refined with solid anthracite aluminum elements
- Warm white and glare-free LED light concept for optimal food presentation in all compartments
- Opening assist for door enabling seamless integration without handles
- Flat dark brushed stainless steel inner door
- Flexible positioning of shelves and door racks through hidden rail system
- Solid anthracite aluminum door bins
- Professional freshness system with 2 fresh climate drawers and 1 chilled drawer
- Internal water dispenser with water filter
- Integrated ice maker with fixed water connection
- Spacious, fully extendable freezer compartment including 2 additional interior drawers
- Full touch TFT display
- ENERGY STAR® certified
- Sabbath mode certified by Star-K
- Net volume 20 cu. ft. (566 liters)

Handling

Opening assist for door.
Cushioned door closing system.
Light and display response to drawer interaction.
Automatic brightness adjustment based on ambient illumination.
Easy accessible full touch TFT display.
Clear text display in 42 languages.
Animated quick guides to assist appliance interaction.

Technical features

Dynamic cold air distribution.
Automatic defrosting with defrost water evaporation.
Constant air purification by 2 activated charcoal air filters.
Sabbath mode certified by Star-K.
Open-door and malfunction warning system.

Selected digital services (Home Connect)

Storage management with cameras.
Personalization function for saving custom programs.
Remote control and monitoring.
Remote diagnostics.

Cooling compartment

Internal water dispenser with water filter.
Professional freshness system.
No-Frost technology with fast cooling.
Temperature adjustable from 35 °F to 46 °F (+2 °C to +8 °C).
3 aluminum-framed safety glass shelves, individually adjustable in height.
1 integrated safety glass shelf with satin matte finish.
Optimal food presentation with warm white and glare-free, hidden LED light bars (3000 K).
Flexible positioning of door racks through hidden rail system.
6 door racks, thereof 4 height adjustable.
Total volume of all refrigerator compartments: 13.2 cu.ft.

Fresh climate drawer

2 fresh climate drawers with humidity control.
Temperature adjustable from 30 °F to 36 °F (-1 °C to +2 °C).
Ideal storage conditions for different foods through dedicated programs (e.g. Fruit, Vegetables, Meat).

RVA 460 020

Accessory for side-by-side installation, backward compatible. Required if a RVY 497 is installed side-by-side with a RY, RB, RC, RF or RW of the Vario cooling 400 series.

Optional accessories

RA 430 100

Storage container with transparent lid, anthracite

Part #11031964

Egg holder insert (for use with RA 430 100)

RA 450 022

Water filter cartridge for ice maker.

Part #11037377

Water filter bypass for home water filtration system

RVA 438 040

Solid oak wood bottle support - set of 1

RVA 450 220

Replacement activated charcoal air filter, set of 2 pcs.

ACLETHST10

Ethylene absorber starter Kit

ACLETHRF10

Ethylene absorber refill kit

Individual adjustment of temperature and humidity.
Extended food preservation with ethylene absorber.
Indirect illumination, transparent front.
Fully extendable, with cushioned closing system.

Chilled drawer

Temperature dependent on cooling compartment (always 2-3 degrees lower).
Indirect illumination, transparent front.
Fully extendable, with cushioned closing system.

Freezer compartment

No-frost technology with fast freezing at -15 °F (-30 °C).
Temperature adjustable from -11 °F to 3 °F (-24 °C to -16 °C).
Freezer burn protection.
Oxidation protection.
Storage time after a malfunction 10 h.
Spacious, fully extendable freezer compartment with synchronously running pull-out rails.
2 extendable interior drawers.
Warm-white, glare-free LED lighting (3000 K) within freezer compartment.
Net volume 6.8 cu.ft.

Ice maker

Integrated automatic ice maker in the freezer compartment, with fixed water connection.
Ice maker can be switched off independently.
Active charcoal water filter for water inlet, integrated in ventilation grill area.
Saturation indicator for filter via full touch TFT display.
Ice cube production approx. 5.5 lb (2.5 kg)/24 h.
Removable ice storage container with approx. 7 lbs. (3.2 kg) capacity.
Integrated, easy accessible ice cube scoop.

Consumption data

Energy consumption 594 kWh/year.
Noise level 39 dB(A) re 1 pW.

Planning notes

Flat hinge.
Door hinge right, reversible.
Door opening angle of 115°, fixable at 90°.
Max. door panel weight:
Each door 141 lbs. (64 kg).
Drawer 30 lbs. (14 kg).
When sabbath mode is active, the appliance can only be opened using a handle.
Shut-off valve for water connection must be planned next to the appliance and always be accessible.
If the water pressure exceeds 116 psi (8 bar), connect pressure relief valve between water tap and hose set.
Standard brushed stainless steel door panels with handles (not dark brushed stainless steel) are available to order, but require a larger 36" (914 mm) wide cutout in order to accommodate the larger doors. Please order RA 421 913 (standard stainless steel doors) and RVA 460 910 (installation accessory). Consult planning notes for additional detail.

Connection

Total rating 1,630 W/24 h.
Total Amps: 10 A.
Connecting cable 118" (3.0 m), detachable.
Cold water connection required.
Electrical location 6" above ground in lower left corner of unit.
Supply hose 70 3/8" (1.8 m) with 1/4" male compression fitting (standard icemaker connector).
Water pressure 29 to 116 psi.



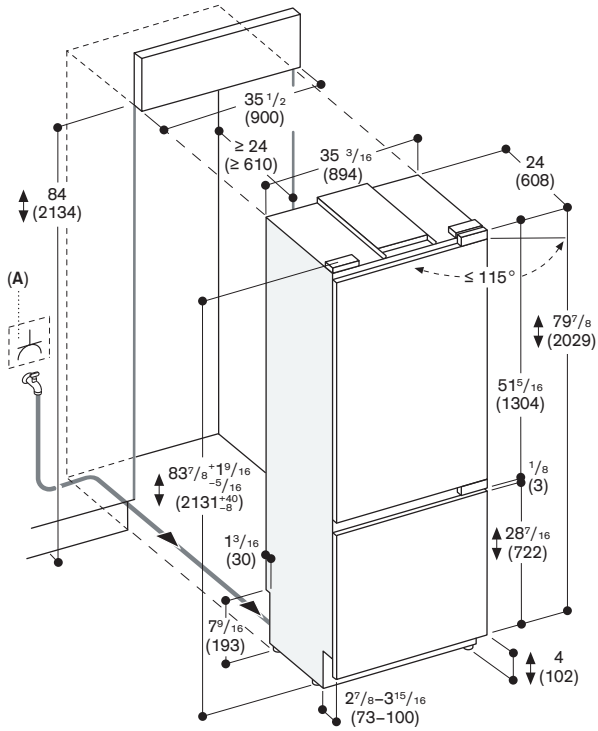

A: Outlet

The maximum door panel dimensions are based on a clearance of $\frac{1}{8}$ " (3 mm)

The height of the toe kick can be reduced to 2" (50 mm)

Measurements in inches (mm)