

USER GUIDE & SERVICE MANUAL



 U-LINE

Model: URNP115-IS01A

USER GUIDE & SERVICE MANUAL

[Click on any section below to jump directly there](#)

Table of Contents

Intro

Safety

Safety and Warning

Disposal And Recycling

Installation

Environmental Requirements

Electrical

Cutout & Product Dimensions

Water Hookup

Drain

General Installation

Integrated Panel Dimensions

Integrated Panel Installation

Door Swing

Door Adjust

Maintenance

Cleaning

Cleaning Condenser

Operating Instructions

First Use

Control Operation

Ice

Airflow and Product Loading

Service

Troubleshooting

Wire Diagram

Product Liability

Parts

R600a Specifications

Compressor Specifications

Warranty

WELCOME TO U-LINE

Congratulations on your U-Line purchase! Our products are focused on functionality, style, and inspired innovations — paying close attention to even the smallest details. Applications include residential, outdoor, ADA height compliant, marine, and commercial. Product categories include Beverage Centers, Wine Refrigerators, Ice Machines, Refrigerators, Freezers, and Dispensers. Our advanced refrigeration systems, large and flexible capacities, and clean integrated look are what makes our products Built-In to Stand Out®. Since 2014, U-Line has been part of the Middleby family of brands.

U-Line — RIGHT PRODUCT. RIGHT PLACE. RIGHT TEMPERATURE.®

PRODUCT INFORMATION

Looking for additional information on your product? User Guides, Spec Sheets, CAD Drawings, and Product Warranty information are available digitally on u-line.com.

PROPERTY DAMAGE / INJURY CONCERNS

In the unlikely event property damage or personal injury is suspected related to a U-Line product, please take the following steps:

1. U-Line Customer Care must be contacted immediately at +1.414.354.0300.
2. Service or repairs performed on the unit without prior written approval from U-Line is not permitted. If the unit has been altered or repaired in the field without prior written approval from U-Line, claims will not be eligible.

GENERAL INQUIRIES

U-Line Corporation
8900 N. 55th Street
Milwaukee, Wisconsin 53223 USA
Monday - Friday 8:00 am to 4:30 pm CST
T: +1.414.354.0300
Email: sales@u-line.com
u-line.com

SERVICE & PARTS ASSISTANCE

Monday - Friday 8:00 am to 4:30 pm CST
T: +1.414.354.0300
Service Email: onlineservice@u-line.com
Parts Email: onlineparts@u-line.com

CONNECT WITH US AT MIDDLEBY REFRIGERATION

Safety and Warning

NOTICE

Please read all instructions before installing, operating, or servicing the appliance.

Use this appliance for its intended purpose only and follow these general precautions with those listed throughout this guide:

SAFETY ALERT DEFINITIONS

Throughout this guide are safety items labeled with a Danger, Warning, or Caution based on the risk type:

DANGER

Danger means that failure to follow this safety statement will result in severe personal injury or death.

WARNING

Warning means that failure to follow this safety statement could result in serious personal injury or death.

CAUTION

Caution means that failure to follow this safety statement may result in minor or moderate personal injury, property, or equipment damage.

DANGER

This unit contains R600a (Isobutane) which is a flammable hydrocarbon. It is safe for regular use. Do not use sharp objects to expedite defrosting. Do not service without consulting the “R600a specifications” section included in the User Guide. Do not damage the refrigerant circuit.

WARNING

Service must be done by factory authorized service personnel. Any parts shall be replaced with like components. Failure to comply could increase the risk of possible ignition due to incorrect parts or improper service.

CALIFORNIA PROPOSITION 65

This product contains chemicals known to the state of California to cause cancer and birth defects or other reproductive harm.

www.P65warnings.CA.gov

CAUTION

This equipment is to be installed with adequate backflow protection to comply with applicable federal, state and local codes.

Disposal and Recycling



RISK OF CHILD ENTRAPMENT. Before you throw away your old refrigerator or freezer, take off the doors and leave shelves in place so children may not easily climb inside.

If the unit is being removed from service for disposal, check and obey all federal, state, and local regulations regarding the disposal and recycling of refrigeration appliances, and follow these steps completely:

1. Remove all consumable contents from the unit.
2. Unplug the electrical cord from its socket.
3. Remove the door(s)/drawer(s).

Environmental Requirements

This model is intended for indoor/interior applications only and is not to be used in installations that are open/exposed to natural elements.

This unit is designed to operate between 50°F (10°C) and 100°F (38°C). Higher ambient temperatures may reduce the unit's ability to reach low temperatures and/or reduce ice production on applicable models.

For best performance, keep the unit out of direct sunlight and away from heat generating equipment.

In climates where high humidity and dew points are present, condensation may appear on outside surfaces. This is considered normal. The condensation will evaporate when the humidity drops.



Damages caused by ambient temperatures of 40°F (4°C) or below are not covered by the warranty.

Electrical



SHOCK HAZARD - Electrical Grounding Required. Never attempt to repair or perform maintenance on the unit until the electricity has been disconnected.

Never remove the round grounding prong from the plug and never use a two-prong grounding adapter.

Altering, cutting or removing power cord, removing power plug, or direct wiring can cause serious injury, fire, loss of property and/or life, and will void the warranty.

Never use an extension cord to connect power to the unit.

Always keep your working area dry.

NOTICE

Electrical installation must observe all state and local codes. This unit requires connection to a grounded (three-prong), polarized receptacle that has been placed by a qualified electrician.

The unit requires a grounded and polarized 115 VAC, 60 Hz, 15A power supply (normal household current). An individual, properly grounded branch circuit or circuit breaker is recommended. A GFCI (ground fault circuit interrupter) is usually not required for fixed location appliances and is not recommended for your unit because it could be prone to nuisance tripping. However, be sure to consult your local codes.

See CUTOUT & PRODUCT DIMENSIONS for recommended receptacle location.

Cutout & Product Dimensions

PREPARE SITE

Your U-Line product has been designed for either free-standing or built-in installation. When built-in, your unit does not require additional air space for top, sides, or rear. However, the front grille must NOT be obstructed, and clearance is required for an electrical connection in the rear.



Unit can NOT be installed behind a closed cabinet door.

If you would like to align the face of the unit with other adjacent cabinet doors, you may need to alter the wall just behind the drain connection on the unit to accommodate the drain.

CUTOUT DIMENSIONS

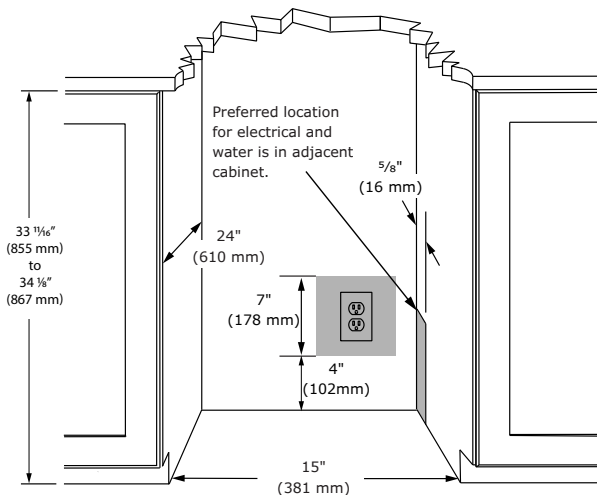

PRODUCT DIMENSIONS

REAR

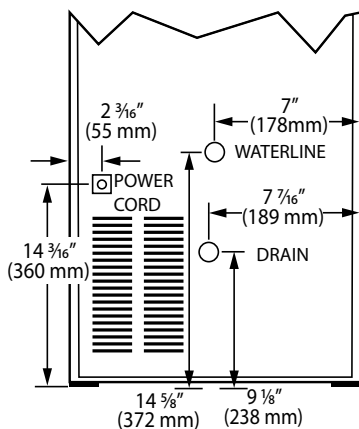

FRONT

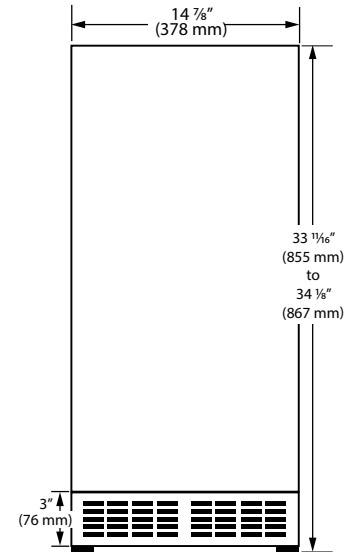

TOP

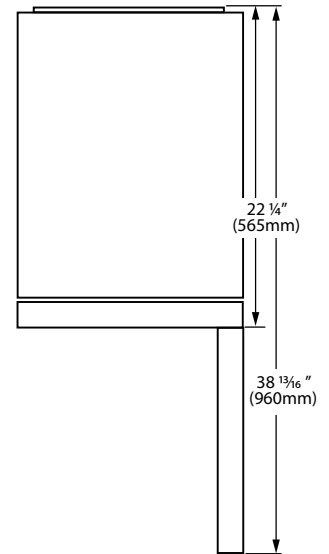

SIDE

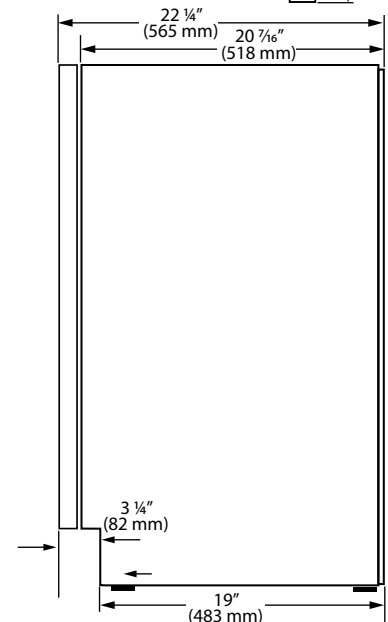

Water Hookup

PREPARE PLUMBING

Plan the arrangement of the water supply pipes.

Connect a 1/4" diameter copper waterline to the tap water supply line. Install a shutoff valve between the tap water pipe and the product so that the user can operate the valve. Do not install the shutoff valve at the back of the product. Do not use a self-piercing valve.

Water quality directly affects performance and product life – use of an in-line water filter is strongly recommended & do not use softened water.

The pressure of the tap water should be maintained at a level between 20psi (1.4bar) and 80psi (5.5bar).

⚠ CAUTION

Plumbing installation must observe all state and local codes. All water and drain connections MUST BE made by a licensed/qualified plumbing contractor. Failure to follow recommendations and instructions may result in damage and/or harm.

Water Supply Connection

When connecting the water supply, please note the following:

- Before installing the unit and connecting to the cold water supply, review the local plumbing codes.
- Softened water is not recommended as it may result in softer ice than desired. If using softened water, install a bypass to supply untreated water to the ice maker.
- Water produced by reverse osmosis and deionized water are NOT recommended. It is more corrosive than tap water and can cause harm to the equipment over time.
- Connection to the water main is made with hose-set only.
- Hose-set must be new, not reused, and in compliance with IEC 61770.
- The water line MUST have a shut-off valve in the supply line.
- The water line should be looped into 2 coils. This will allow the unit to be removed for cleaning and servicing. Make certain that the tubing is not pinched or damaged during installation.

⚠ CAUTION

Do not use any plastic water supply line. The line is under pressure at all times. Plastic may crack or

rupture with age and cause damage to your home. Do not use tape or joint compound when attaching a braided flexible water supply line that includes a rubber gasket. The gasket provides an adequate seal – other materials could cause blockage of the valve.

Failure to follow recommendations and instructions may result in damage and/or harm, flooding or void the product warranty.

Use new hose set. Do not reuse old hose set.

⚠ CAUTION

Turn off water supply and disconnect electrical supply to unit prior to installation.

Use caution when handling back panel. The edges could be sharp.

INSTALL WATER SUPPLY

1. Install the inlet pipe (1/4" diameter copper pipe) on the wall and connect the water supply valve.
2. Use the inlet pipe after cutting it to the required length.
3. Wash the inlet pipe.
4. Connect the inlet pipe with the copper pipe using the flare nut.
5. Connect the inlet pipe with the water-supply valve of the product using the flare nut.
6. Turn on the tap and check for any leakage.

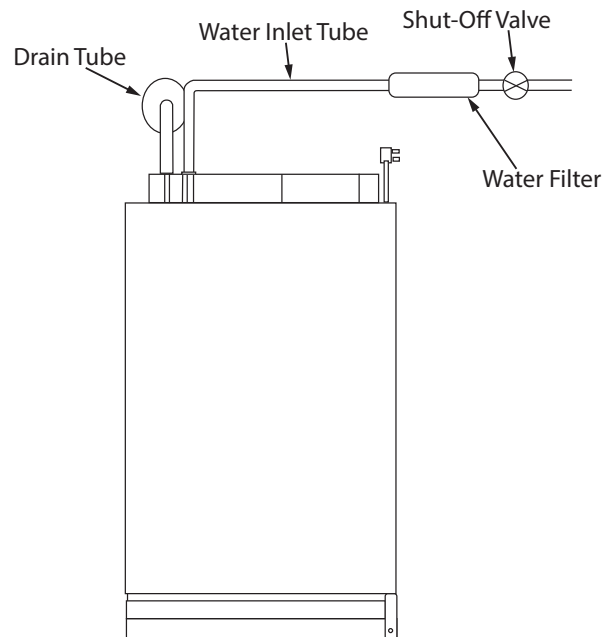

Drain

SECURE DRAIN HOSE TO BACK PANEL

CAUTION

Do not pull or bend the drain hose to avoid damage to drain pump. Drain hose must be secured to the rear of the machine before connecting to drain.

1. Find hose clamp and screw in the literature package that came with your machine.
2. Secure hose using supplied clamp and screw.

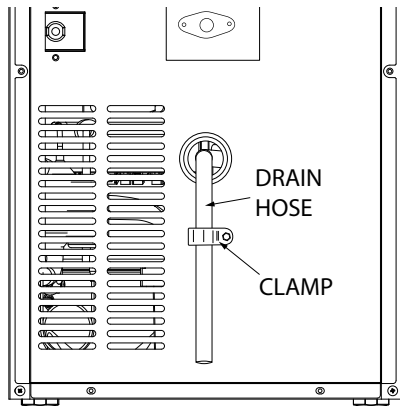

DRAIN CONNECTION

CAUTION

Failure to connect water supply or drain line connections properly can result in personal injury and property damage. Do not pull the drain hose to avoid damage to drain pump.

CAUTION

The floor drain must be large enough to accommodate drainage from all attached drains. Follow these guidelines when installing drain lines to prevent water from flowing back into the ice maker storage bin and/or potentially flowing onto the floor, which may result in personal injury or property damage

NOTICE

Drain can NOT be located directly below the unit. Unit has a solid base that will not allow the unit to drain below itself.

There is a possibility that hose connections may have loosened during shipment. Verify all connections and fittings are free from leaks.

CAUTION

This equipment is to be installed with adequate backflow protection to comply with applicable federal, state and local codes

HOOKUP DRAIN PUMP

See below for typical installations.

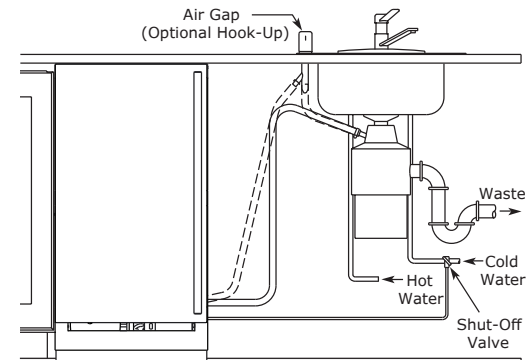
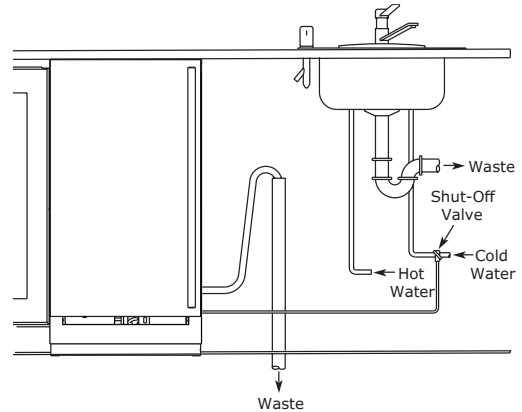

Y-Branch Tailpiece
Drain Pump

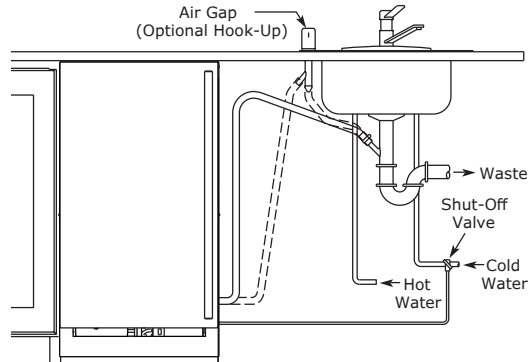

NOTICE

The maximum lift for the drain pump is 10 feet. This must be done as close to the rear of the unit as possible.

General Installation

LEVELING INFORMATION

1. Use a level to confirm the unit is level. Level should be placed along top edge and side edge as shown.

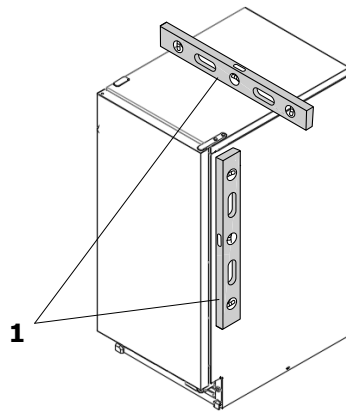

2. If the unit is not level, adjust the legs on the corners of the unit as necessary.

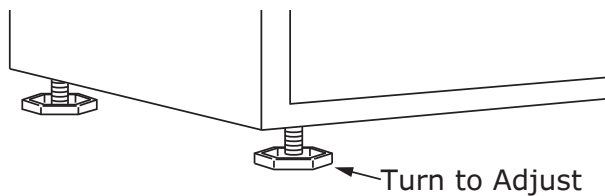

3. Confirm the unit is level after each adjustment and repeat the previous steps as needed.

INSTALLATION TIP

If the room floor is higher than the floor in the cutout opening, adjust the rear legs to achieve a total unit rear height of $\frac{1}{8}$ " (3 mm) less than opening's rear height. Shorten the unit height in the front by adjusting the front legs. This allows the unit to be gently tipped into the opening. Readjust the front legs to level the unit after it is correctly positioned in the opening.

INSTALLATION

1. Plug in the power/electrical cord.
2. Gently push the unit into position. Be careful not to entangle the cord or water and drain lines, if applicable.
3. Re-check the leveling, from front to back and side to side. Make any necessary adjustments. The unit's top surface should be approximately $\frac{1}{8}$ " (3 mm) below the countertop.
4. Remove interior packing material and wipe out the inside of the unit with a clean, water-dampened cloth.

Integrated Panel Dimensions

INTEGRATED PANEL

NOTICE

Due to differences in surrounding cabinetry, the panel may not perfectly align with door. The procedure below is designed to prepare a finished integrated panel that seamlessly integrates with surrounding cabinetry.

The door panel must not weigh more than 20 lbs (10 kg).

It is important to ensure that all drilled holes are drilled to the correct depth in order to avoid splits in the wood when hardware is installed.

When applying an integrated panel to a unit ensure that both sides are finished in order to prevent warping.

A full integrated door panel completely covers the door frame and provides a built-in appearance.

Integrated Panel Preparation

1. Cut the panels to the dimensions listed in the diagram below. For optimal results, have a qualified carpenter verify all measurements.
2. Optional: Stain or Finish panel to desired stain or color. Be sure to closely follow the instructions provided by the manufacturer.
3. Optional: Install handles and hardware.

Integrated Panel Dimensions

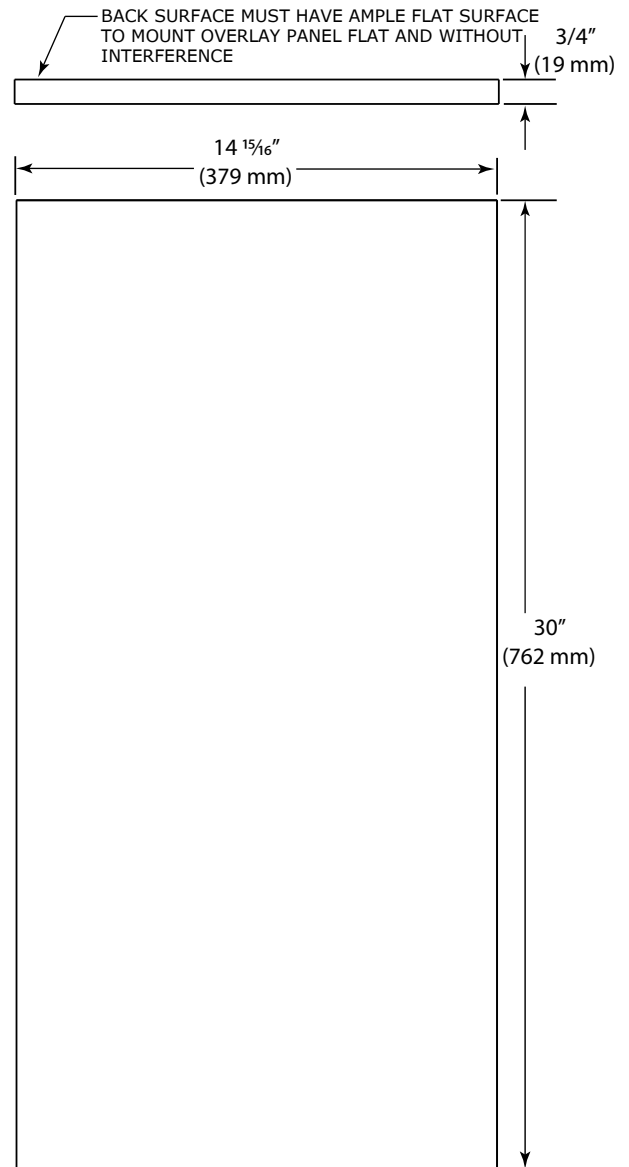

Integrated Panel Installation

PREPARE INTEGRATED PANEL

1. Remove door from unit
(See To Reverse the Door Swing)
2. On a flat surface, line up the door to the integrated door panel and clamp.
3. Remove gasket and gasket channel filler to expose side holes.
4. Install 10 screws to secure door to panel.
 - 6 - 3/4" #8 Pan Head Screws
 - 4 - 1/2" #8 Pan Head Screws

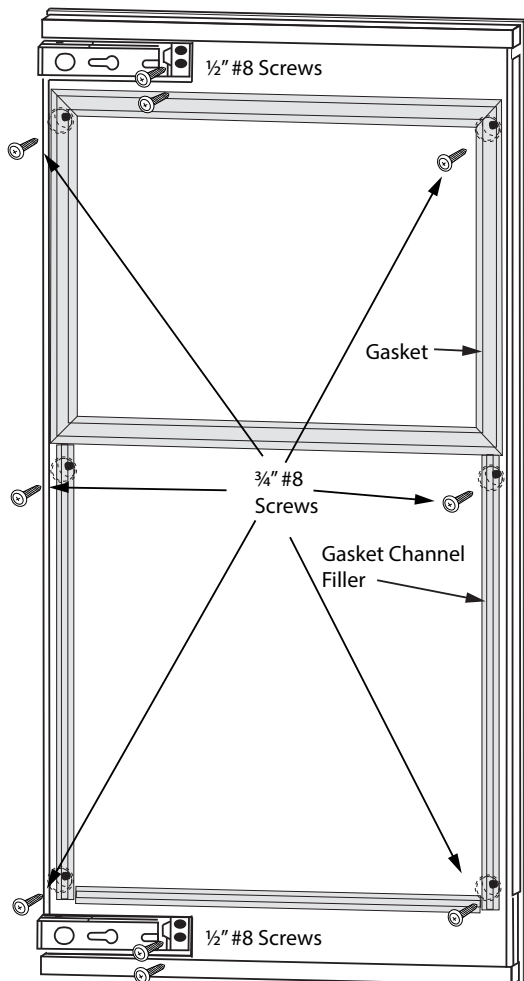

5. Reinstall gasket channel filler.
6. Remove clamps.
7. Reinstall door to unit.

(See To Reverse the Door Swing)

Stainless Panel Installation

Stainless Steel panel is an accessory that is sold separately. Please Visit U-Line.com for details.

1. Remove gasket and gasket channel filler to expose side holes.
2. Line up holes in door with holes in stainless steel panel.

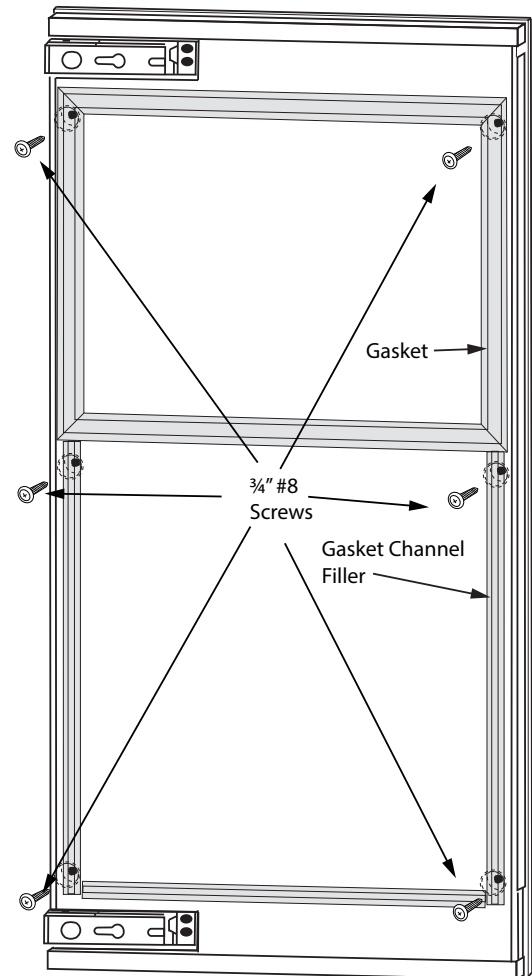

3. Install 6 - 3/4" #8 screws to secure panel to door.
4. Reinstall gasket and gasket channel filler.

Door Swing

This unit is equipt with a door that opens past 90°. For this reason, it will be necessary to carefully plan where the unit is installed in relationship to walls and surrounding appliances.

The ONP115 door opens to a maximum of 105°.

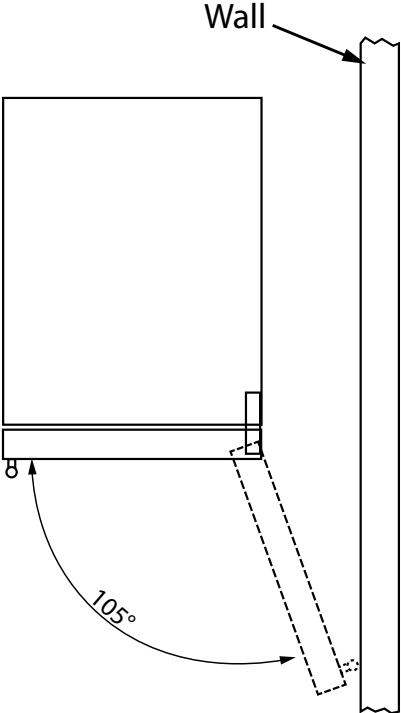

Door Adjustments

REVERSE DOOR SWING

The hinges are attached to the right-hand side of the door when the product is shipped from the factory. However, the ice maker is designed so that the hinges may be installed on either side. If the hinges are moved to the left-hand side, the door will open to the left.

To Reverse the Door Swing

Remove Door

1. On both hinges, loosen **but do not remove** the outside screws.
2. Remove the inside screws.
3. Carefully shift the door to the right to free the hinges from the loosened screws. Set door aside, with hinges still attached.
4. Tighten the screws.

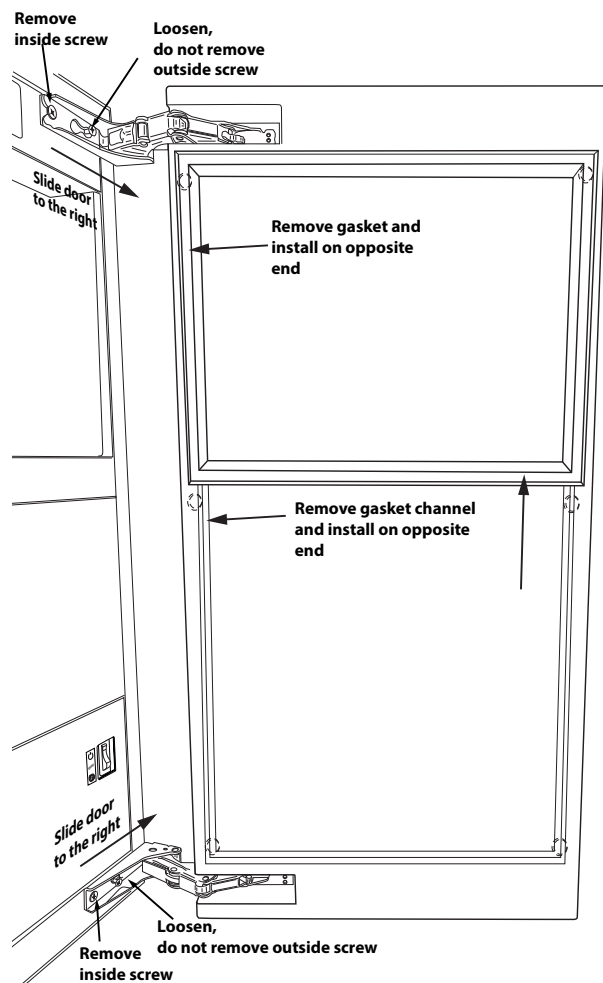

Prepare Door

1. Rotate door 180°.
2. Remove gasket and gasket channel cover.
3. Install gasket and gasket channel cover on opposite end of door.

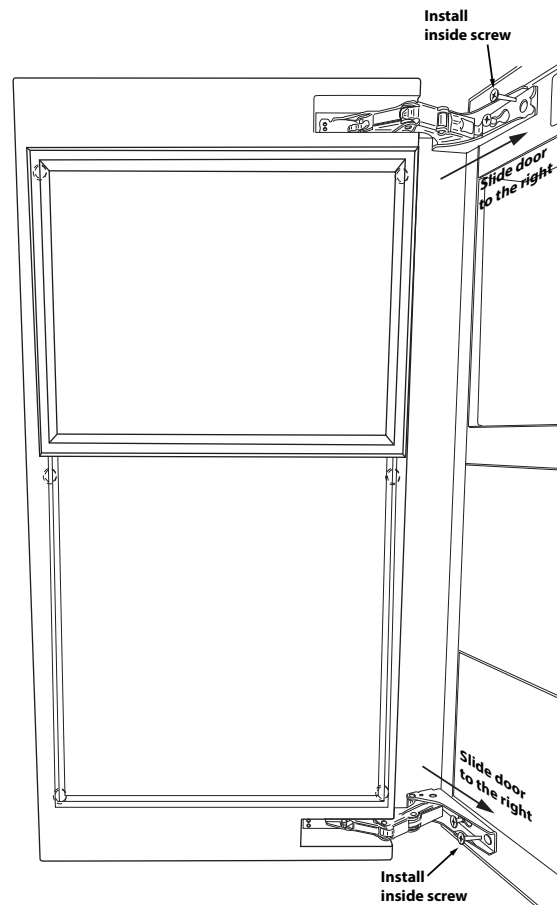

Install Door

1. On the opposite side of the cabinet, loosen **but do not remove** the outside screws.
2. Remove the inside screws.
3. Line up the holes on the hinges with the loosened screws and slide door all the way to the left.
4. While still holding door, install the remaining screws.
5. Tighten all 4 screws.
6. Check door for proper swing.

First Use

INITIAL STARTUP

1. Turn on the water supply to the ice maker.
2. Connect ice maker to power source.
3. Open door and locate the switch at the bottom area of the machine.
4. Set the switch to .
5. The ice maker will begin to produce ice.
6. Discard the first 2 batches of ice.

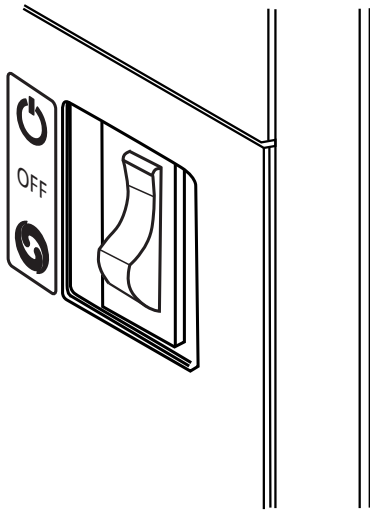

USER GUIDE

DISPLAY PANEL

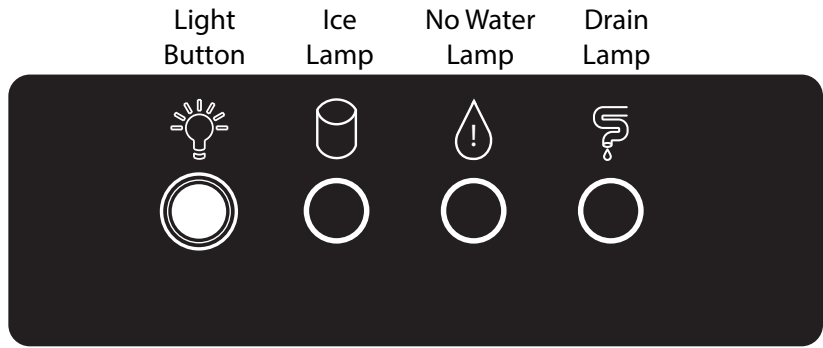
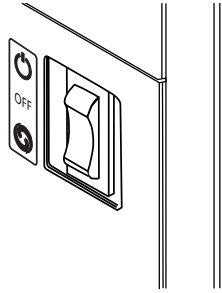

CONTROL FUNCTION GUIDE

| FUNCTION | COMMAND | NOTES |
|---------------|--|-----------------------|
| Light Button | Press and release | Light turns on or off |
| Ice Lamp | Lights up when operation switch is set to "ICE" | |
| No Water Lamp | Lights up to indicate low water supply | |
| Drain Lamp | Lights up to indicate activation of the drain valve. | |

NOTE:

When door is closed, interior UV light comes on.

Ice

⚠ CAUTION

Do not put anything other than ice in the ice bin. Wine or beer bottles are unsanitary and a detached label may block the drain.

⚠ CAUTION

If the ice storage bin is full of water, turn off the ice maker and clean the mesh on the bottom of the ice bin.

Ice-Making Process

Water flows into the drum, and as the auger rotates, the water freezes and is ejected upward. Impurities in the water are periodically discharged by the drain valve to create clean ice.

Operation Time

The machine continues to operate until the ice bin is full, which takes about 10 hours. (This time will vary slightly based upon ambient and water temperatures.)

The machine ceases ice production when the ice level reaches the temperature sensing tube located on the right side.

⚠ CAUTION

When the door is open, the ice maker cannot detect if the bin is full. Be sure to keep door closed during ice production.

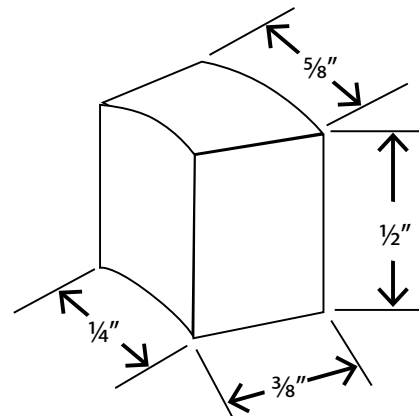

Approximate size and shape of a cube.
(Image not to scale)

Airflow

NOTICE

The unit requires proper airflow to perform at its highest efficiency. Do not block the front grille at any time, or the unit will not perform as expected. Do not install the unit behind a door.

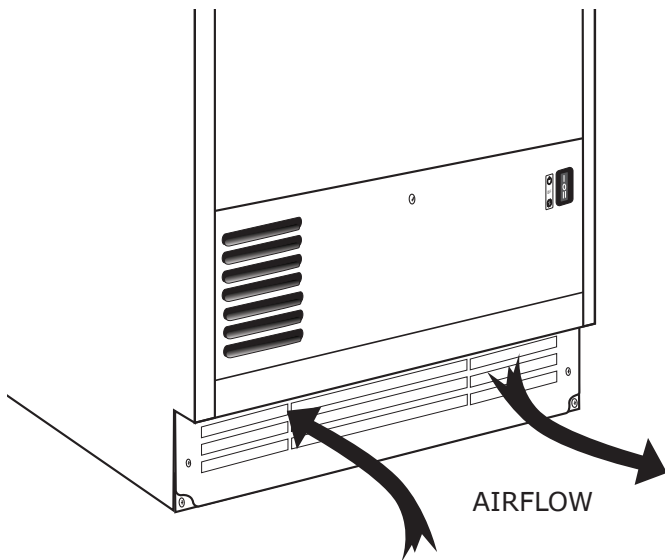

Cleaning

NOTICE

Use only U-Line Ice Machine Cleaner (80-55667-00), available for purchase from u-line.com or your dealer. It is a violation of federal law to use this solution in a manner inconsistent with its labeling. Use of any other cleaner can cause damage to the ice machine and will void the warranty. Read and understand all labels printed on the package before use.

U-Line Ice Machine Cleaner is used to remove lime scale and other mineral deposits. Refer to the following steps to initiate the self-cleaning cycle.

Internal Cleaning

1. Dilute 2 oz. of Ice Machine Cleaner into two quarts of water.
2. Open the door and pour approximately 1 quart (1 liter) of cleaning solution into the ice spout.
3. Toggle the lower front mode switch to .

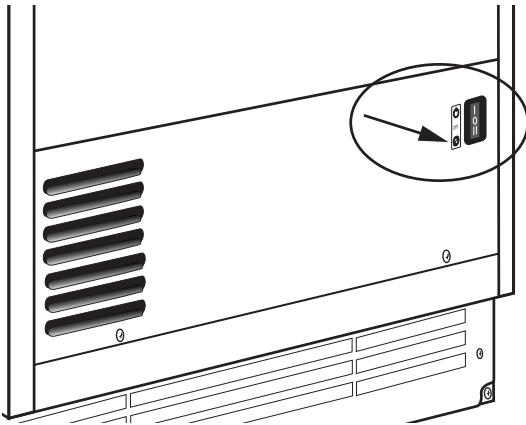

4. The ice maker automatically cleans, drains, and supplies water repeatedly, which takes about 10 minutes.
5. Use a sponge or cloth to clean the inside of the reservoir with the remaining cleaning solution.
6. After 10 minutes, rinse the inside of the reservoir with clean water, pouring some water into the ice spout.
7. Toggle the mode switch to  again.
8. After about 10 minutes, the cleaning processes will be completed.

External Cleaning

If the surface of the door and lever become stained, clean immediately. If the door and/or gasket have spots on the surface, remove the spots using soap and warm water with a non-abrasive cloth or sponge. For stainless steel exterior, use a soft and non-abrasive stainless steel cleaner (such as the liquid variety of Barkeeper's Friend) and a soft lint-free cloth.

Clean the Ice Bin

The ice bin should also be cleaned regularly.

Combine 1 ounce of bleach with 2 gallons of warm water at 95°F - 115°F (35°C - 45°C) to use as a cleaning solution. Dampen a clean cloth with the cleaning solution and wash the inside of the ice bin. Pour a small quantity of the solution into the drain Pipe, then dry the interior.

Cleaning the Condenser

⚠ WARNING



Disconnect electric power to the unit before cleaning the condenser.

DO NOT use any type of cleaner on the condenser unit. Condenser may be cleaned using a vacuum, soft brush, or compressed air.

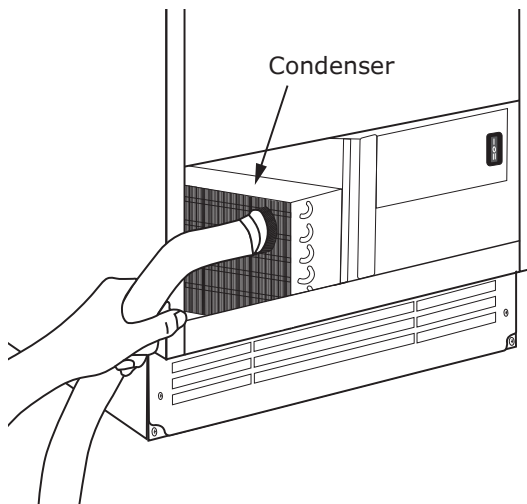
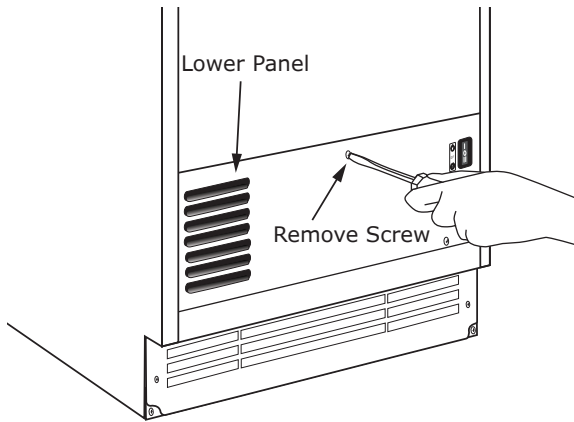
The condenser should be cleaned 2-3 times a year to remove any lint that has penetrated the condenser. When cleaning the condenser, remove the front lower panel. Then, remove any dust and lint from the condenser using a soft bristle brush. For the position of the condenser, refer to the drawing.



Troubleshooting

| CURRENT CONDITION | LAMP | | | CAUSES | ACTION |
|-------------------------------------|----------|------------------|------------|---|--|
| | ● ICE | ● NO WATER | ● DRAIN | | |
| Ice Making | L | | | When the operation switch is switched to the  position. | |
| Washing | B | | | When the operation switch is changed to  , the 'ICE' lamp blinks (every 1 second). | When you turn the operation switch to the 'off' position, the water will drain and stop after performing the cleaning procedure. |
| Ice Full (Storage bin) | B | | | When the storage bin is full of ice (Ice Lamp on every 2 seconds, turns off for 1 second repeatedly). | |
| Drain valve operating | | | L | When the drain valve opens. | |
| Water supply error | | B | | When water level is not detected by the water level sensor due to no water supply for 2 minutes. (Er15). Automatically resets after 5 minutes. | Water supply pressure check. Water level sensor check. Start operation after action. |
| Water drain error | | | B | If the lower limit water level sensor is not detected within 2 minutes as the drain valve operates (Er16). Automatically resets after 5 minutes. | Replacement of water level sensor. Check drain valve operation. Check for clogged drain. Start operation after action. |
| Evaporator temperature | B | B | B | When the Evaporator temperature is 32°F or more after 30 minutes passed during the ice making (Er01). | Check refrigerant leakage. Check sensor and attachment. abnormality. Resupply power after resolving cooling problem. |
| Evaporator temperature error | B | | | When the Evaporator temperature is 32°F or more after 10 minutes passed during the ice making (Er03). | |
| Ice full sensor error | | B | B | When the ice full temperature sensor in the storage bin is disconnected or shorted. | Check sensor and attachment abnormality. Start operation after sensor part repair. |
| Evaporator temperature sensor error | B | B | | When the EVA temperature sensor at the evaporator outlet is disconnected or shorted. | |
| Air temperature sensor | B | | B | When the air temperature sensor in front of the condenser is disconnected or shorted. | |
| Evaporator freezing | L | L | L | When the evaporator outlet temperature drops below -7.6° F while the ice maker is running (Er25) | Operate when the ambient temperature is over 50°F. |

*L = Lamp On; B =Lamp Blinking

USER GUIDE

- The following maintenance schedule is guideline
- Maintenance and repair should be done more frequently according to water quality, equipment usage environment and local hygiene regulations.

| Maintenance Schedule | | |
|----------------------------|--|--|
| Frequency | Area | Task |
| Daily | Scoop | Clean the scoop using a neutral cleaner. Rinse thoroughly after cleaning. |
| Monthly | External water filter | Make sure that the pressure is adequate and make changes if needed. |
| | Outside of the ice maker | Wipe down with clean, soft cloth. Use a damp cloth containing a neutral cleaner to wipe off oil or dirt build up. Clean any chlorine staining (rustcolored spots) using a non-abrasive cleanser. |
| | Storage Bin, Inner door, Ice outlet(Spout) | Wipe clean with clean cloth and warm water. |
| Every 6 Months | Icemaker and Storage Bin | Clean and disinfect according to the disinfection instructions given in the instruction manual. |
| | Evaporator Condensate Drain Pan and Gear Motor Drain Pan | Wipe down with clean cloth and warm water. |
| | Ice maker and reservoir | Always check that it is kept clean. |
| | Ice exit fixing seal bolt | Check for leaks around the seal bolt. Tighten if necessary and replace O-rings. Always replace the O-ring when loosening the seal bolt and tighten it again. If there is no O-ring, apply Loctite 243 or equivalent fixing agent so that it does not leak. |
| | Condenser (air-cooled) | Inspect for cleaning. If necessary, clean with a brush or vacuum cleaner If the dust adhesion is severe, spray the pin cleaning agent, clean the dust, spray it with clean water, rinse and dry with air gun. Clean condenser every 6 months. |
| Yearly | Water supply valve and Drain valve | Close the shutoff valve to shut off the water supply line and drain the water. |
| | Water hose | Check the water hose and clean it if necessary. |
| | Ice maker | Inspect for oil marks, loose components, tightening parts and wires. |
| | Upper bearing (Ice exit head) | Check that 0.02" round bar or pin gauge (or clearance gauge) is inserted into auger and bearing clearance, and replace all upper and lower bearings (ice exit head and lower housing) |
| | Mechanical seal | Check for leaks in the bottom housing, and if there is a leak, disassemble the auger to replace the mechanical seal. (Water with a lot of calcium will shorten the life of replacement parts.) |
| After 3 Years, then Yearly | Upper and lower bearings, Housing O-ring, Mechanical seals, Evaporator cylinder, Auger | Please check. If the auger and bearing clearance exceeds the factory recommended value (0.02" or less), replace both the upper and lower bearings. If the contact surface of the mechanical seal is worn, cracked, or scratched, replace it. |

USER GUIDE

Wire Diagram

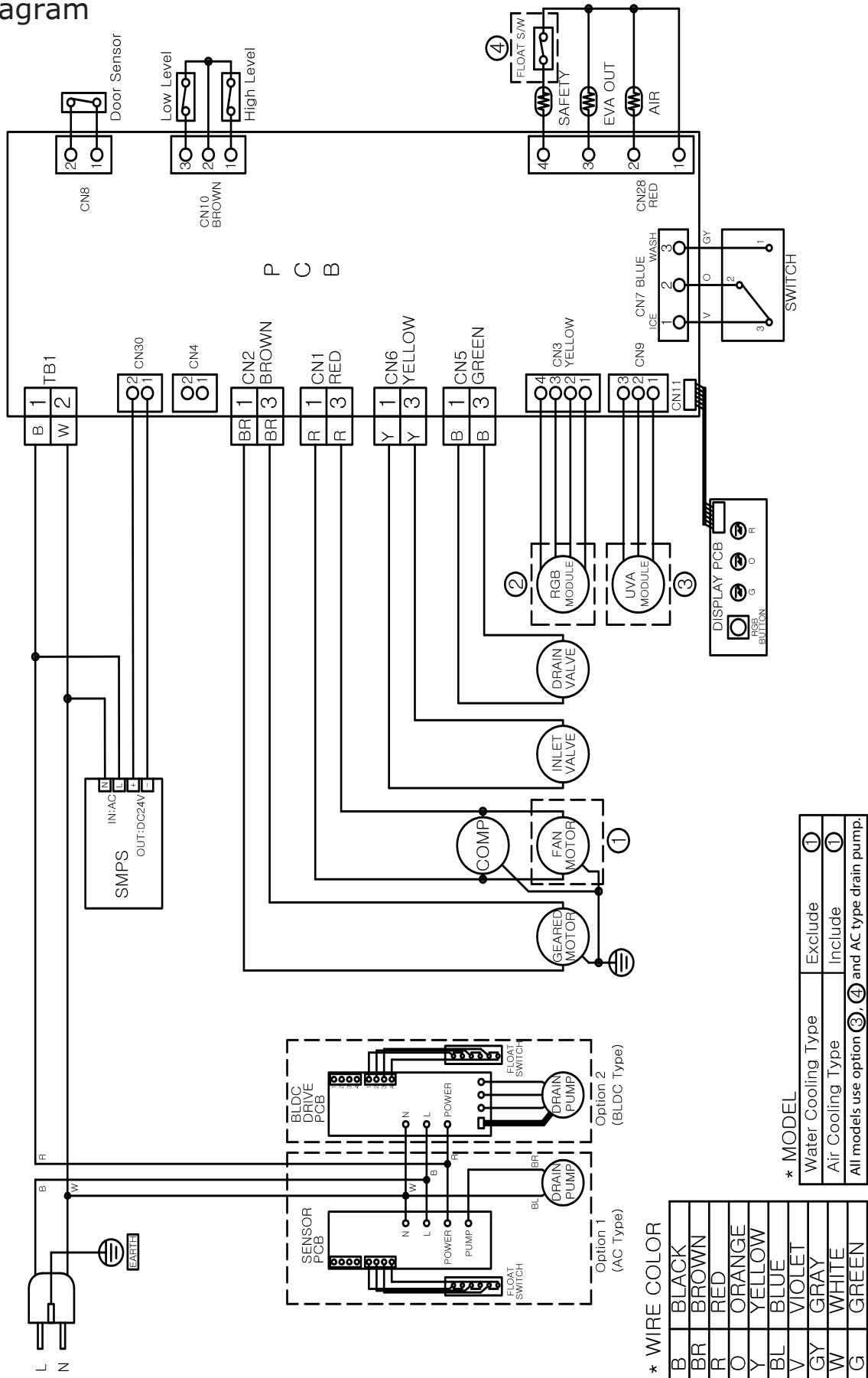

Product Liability

Field service technicians are authorized to make an initial assessment in the event of reported damages. If there are any questions about the process involved, the technician should call U-Line for further explanation.

While inspecting for defects or installation issues, photos should be taken to document any damages or issues found.

During the assessment, if the service technician is able to find the source of the damage and it can be resolved by replacement of a part, the servicer is authorized to replace the part in question. The part that caused the damage must be returned to U-Line in its entirety. The part must be clearly labeled with the serial number of the unit it was removed from, the date, and the servicer who removed the part.

If the service technician determines the damage is the result of installation issues (water connection/drain, etc.), the consumer would be notified and the issues shall be resolved at the direction of the consumer.

If damage is evident and the service technician is unable to find the source, U-Line must be contacted at +1.414.354.0300 for further direction.

8900 N. 55th Street • Milwaukee, WI 53223

T: +1.414.354.0300 • F: +1.414.354.5696

Website: www.u-line.com

**Right product. Right place.
Right temperature Since 1962.**

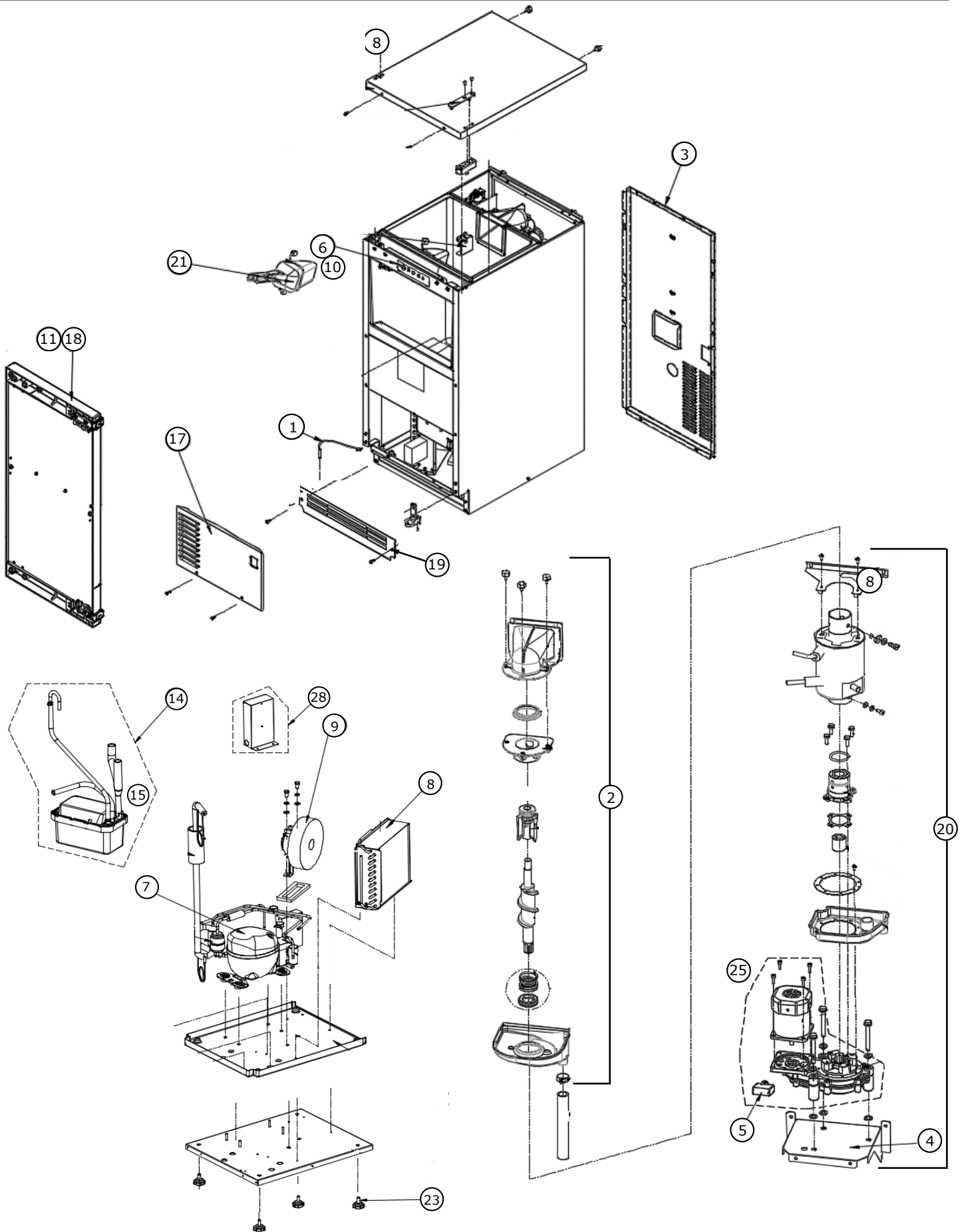

| | | |
|----|------------------------------|-------------|
| 1 | AIR SENSOR (BLUE) | 80-55453-06 |
| 2 | AUGER ASSEMBLY | 80-55381-02 |
| 3 | BACK PANEL (REAR COVER) | 80-55342-09 |
| 4 | BASE BRACKET(G-BOX) | 80-55342-01 |
| 5 | CAPACITOR KIT | 80-55453-05 |
| 6 | COMPLETE CONTROL KIT | 80-55398-07 |
| 7 | COMPRESSOR ASSEMBLY | 80-55453-04 |
| 8 | CONDENSER ASSEMBLY | 80-55453-02 |
| 9 | CONDENSER FAN ASSEMBLY | 80-55453-03 |
| 10 | DISPLAY ASSEMBLY | 80-55398-06 |
| 11 | DOOR ASSEMBLY SOLID W/HINGES | 80-55354-01 |
| 12 | DRAIN ASSEMBLY | 80-55227-04 |
| 13 | DRAIN KIT FOR PUMP | 80-55227-07 |
| 14 | DRAIN PUMP ASSEMBLY | 80-55227-03 |
| 15 | DRAIN PUMP ASSY(BLDC) | 80-55227-01 |
| 16 | EVAPORATOR ASSEMBLY | 80-55381-01 |

| | | |
|----|---------------------------------|-------------|
| 17 | FRONT LOW-COVER KIT: PIN TYPE | 80-55342-08 |
| 18 | GASKET DOOR ASSY (SOLID) | 80-55453-08 |
| 19 | GRILLE ASSEMBLY (OUTDOOR) | 80-55342-07 |
| 20 | ICE MAKING UNIT (NUGGET) | 80-55381-03 |
| 21 | ICE SCOOP ASSEMBLY | 80-55352-00 |
| 22 | INLET SOCKET ASSEMBLY | 80-55227-08 |
| 23 | LEVELING LEGS | 80-55342-02 |
| 24 | MAGNET ASSEMBLY | 80-55342-04 |
| 25 | MAIN BOARD KIT | 80-55398-09 |
| 26 | MOTOR+GEAR BOX ASSY(1:200, 40W) | 80-55381-04 |
| 27 | POWER CORD ASSEMBLY* | 80-55398-10 |
| 28 | SMPS BOX KIT | 80-55398-08 |
| 29 | U-PIPE ASSEMBLY | 80-55381-05 |
| 30 | WATER INLET VALVE ASSEMBLY | 80-55227-05 |
| 31 | WATER RESERVOIR ASSEMBLY | 80-55381-06 |
| 32 | WATER VALVE ASSEMBLY | 80-55227-06 |

* Not Pictured

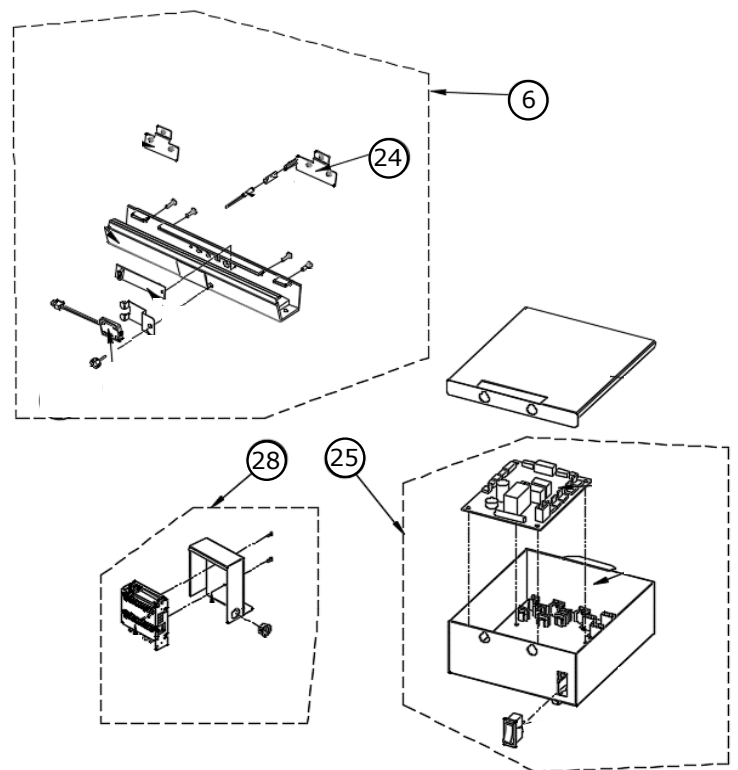

USER GUIDE

R290/R600A Specifications

For R290/R600a refrigerant service tips and more videos, go to: www.u-line.com/videos.

⚠ WARNING

Flammability warnings for a pure-iso-butane/propane refrigerant.



Gloves and Eye Protection must be used.



R290/R600a is considered non-toxic, but is flammable when mixed with air.

Keep a dry powder type fire extinguisher in the work area.



R290/R600a is heavier than air, do not allow any leakage/migration to low areas such as basements and stairs.

Never use a torch on a fully charged refrigeration system.

Never substitute U-Line OEM replacement parts or methods of construction.

R290/R600a must be stored and transported in approved containers.

WARNING

Only skilled and well trained service technicians permitted to service R290/R600a equipped products.

All tools and equipment must be approved for use with R290/R600a refrigerant.

Local, state and federal laws, standards must be observed along with proper certification and licensing.

Ventilation is required during servicing.

No conversions to R290/R600a from any other refrigerants. OEM R290/R600a equipped unit only.

Service area must be free of ignition sources.

No smoking is allowed in the service area.

All replacement electrical components must be OEM and installed properly (sealed and covered).

If the evaporator is cold prior to service, it must be thawed prior to service.

When using a vacuum pump, start pump before opening refrigeration system.

Vacuum pump and recovery equipment should be at least 10 feet from the work area.

It is recommended that a simple LPG gas detector is on site during service.

Ensure that all R290/R600a is removed from the system prior to brazing any part of the sealed system.

Only a clean, dry, leak-free system should be charged with R290/R600a.

R290/R600a SPECIFICATIONS/LABELING

R290/R600a equipped products are labeled (both the unit and the compressor).

R290/R600a is colorless and odorless.

R290/R600a is considered non-toxic, but is flammable when mixed with air.

Do not remove or alter any R290/R600a labeling on the product.

Use only a refrigerant grade R290/R600a from a properly labeled container.

RECOVERING/RECLAIMING R290/R600a

(R290/R600a has been exempted from recovery/reclaiming requirements by the US EPA)

Recovery/Reclaiming equipment must be approved for use with R290/R600a.

Ensure the evaporator is at room temperature prior to recovery/reclaiming R290/R600a.

Use a common piercing pliers or piercing valve to remove R290/R600a from the compressor process tube. (Note: Piercing devices must not be left on the system and must be replaced with a Schrader type valve.)

USER GUIDE

Evacuate/reclaim via the piecing pliers to ensure the system is empty of R290/R600a before any system work is performed.



The recovery cylinder must be evacuated (no air inside) prior to accepting R290/R600a.

The recovery cylinder must not be filled more than 45% safe fill level and refrigerants must not be mixed.

The recovery cylinder must be clearly marked with R290/R600a and Flammable Warning labels.

Ensure proper ventilation during recovery/reclaiming of R290/R600a.

Start vacuum pump/recovery pump prior to piercing the compressor process tube.

Follow recovery/reclaim OEM instructions for the specific equipment used.

SYSTEM REPAIR

Ensure no residual R290/R600a refrigerant is left within the system prior to repair (simple venting is not sufficient).

Evacuate and charge with dry nitrogen for leak checks.

Repair leaks or replace system parts as required.

When re-brazing, the system must be purged with dry nitrogen and at least one access point open to the atmosphere.

When re-brazing, proper ventilation is required along with constant monitoring for the presence of R290/R600a refrigerant.

The filter dryer must be replaced any time the sealed system is serviced.

No system should be open to the atmosphere for longer than 15 minutes to avoid moisture migration into the system components.

LEAK DETECTION

After removal of the R290/R600a, the unit can be charged with dry nitrogen or helium.

Electronic leak detection or soap solution can be used to check for nitrogen/helium leaks. Evacuate and charge with dry nitrogen for leak checks.



Never use a halide torch or lighted match to check the system for leaks at any time.

The high side of the refrigeration system (compressor discharge to outlet of drier) must be leak tested with the compressor running.

USER GUIDE

The low side of the refrigeration system (evaporator, compressor and suction line) must be leak tested with the compressor off (equalized pressure).

RECHARGING

No air is ever to be allowed inside the refrigeration system (R-600a refrigerant or dry nitrogen only).

Never use a torch on a fully charged refrigeration system.

Install a Schrader Type access port on the compressor process stub.



Evacuate the system to 100 microns prior to charging. Weigh in the R290/R600a charge using a refrigerant scale. (run compressor an extra two minutes to clear the charging hoses).

Seal the Schrader Type access port, a proper cap and seal must be used to close the system.

No system should be open to the atmosphere for longer than 15 minutes to avoid moisture migration into the system components.



SUMMARY

Safely handling R290/R600a requires proper procedures and training.

R290/R600a approved service tools must be used.

R290/R600a labeling must not be removed or altered.

Proper ventilation during service is required.

Never apply a torch to a charged R290/R600a refrigeration system.

Use OEM replacement service parts and do not alter the construction of the unit.

No air is ever to be allowed inside the refrigeration system (R290/R600a refrigerant or dry nitrogen only).

Never use a torch on a fully charged refrigeration system. Install a Schrader Type access port on the compressor process stub.

The filter dryer must be replaced any time the sealed system is serviced.

No system should be open to the atmosphere for longer than 15 minutes to avoid moisture migration into the system components.

LEAK DETECTION

After removal of the R290/R600a, the unit can be charged with dry nitrogen or helium.

Electronic leak detection or soap solution can be used to check for nitrogen/helium leaks. Evacuate and charge with dry nitrogen for leak checks.

Compressor Specifications



Electrocution can cause death or serious injury. Burns from hot or cold surfaces can cause serious injury. Take precautions when servicing this unit.

Disconnect the power source.

Do not stand in standing water when working around electrical appliances.

Make sure the surfaces you touch are not hot or frozen.

CHECK TERMINAL PINS

To measure the start winding resistance, measure across the C and S pins.

To measure the run winding resistance, measure across the C and R pins.

Also check S to R and you should get the sum of the run and start windings.

To ensure the windings are not shorted, check the S and R to ground.

| | HYS67MGU72a |
|-----------------|--------------------|
| Refrigerant | R600a |
| Voltage | 115 - 127 VAC |
| Frequency | 60 Hz |
| Run Cap | 8 μ F/450 VAC |
| Start Winding | 8 Ohm at 77°F |
| Run Winding | 7.1 Ohm at 77°F |
| LRA | 11 A |
| FLA | 7.6 A |
| Starting Device | QP2-4R7 |
| Overload | DRB26p61A1 |

* All resistance readings are $\pm 10\%$

U-Line Corporation (U-Line) Limited Warranty

One Year Limited Warranty

For one year from the date of original purchase, this warranty covers all parts and labor to repair or replace any part of the product that proves to be defective in materials or workmanship. For products installed and used for normal residential use, material cosmetic defects are included in this warranty, with coverage limited to 60 days from the date of original purchase. All service provided by U-Line under the above warranty must be performed by a U-Line factory authorized servicer, unless otherwise specified by U-Line. Service provided during normal business hours.

Two Year Limited Warranty (5 Class Product)

For two years from the date of original purchase, this warranty covers all parts and labor to repair or replace any part of the product that proves to be defective in materials or workmanship. For products installed and used for normal residential use, material cosmetic defects are included in this warranty, with coverage limited to 60 days from the date of original purchase. All service provided by U-Line under the above warranty must be performed by a U-Line factory authorized servicer, unless otherwise specified by U-Line. Service provided during normal business hours.

Available Second & Third Year Limited Warranty

In addition to the standard one and two year warranties outlined above, U-Line offers a one year extension of the warranties from the date of purchase, free of charge. To take advantage of this extension, you must register your product with U-Line within 60 days from the date of purchase at u-line.com and provide proof of purchase. Nugget Ice Machine proof of purchase must include the purchase of an in-line water filter and filter head to qualify for this additional limited warranty.

Five Year Sealed System Limited Warranty

For five years from the date of original purchase, U-Line will repair or replace the following parts, labor not included, that prove to be defective in materials or workmanship: compressor, condenser, evaporator, drier, and all connecting tubing. All service provided by U-Line under the above warranty must be performed by a U-Line factory authorized servicer, unless otherwise specified by U-Line. Service provided during normal business hours.

Terms

These warranties apply only to products installed in any one of the fifty states of the United States, the District of Columbia, or the ten provinces of Canada. The warranties do not cover any parts or labor to correct any defect caused by negligence, accident or improper use, maintenance, installation, service, repair, acts of God, fire, flood or other natural disasters. The product must be installed, operated, and maintained in accordance with your product's User Guide.

The remedies described above for each warranty are the only ones that U-Line will provide, either under these warranties or under any warranty arising by operation of law. U-Line will not be responsible for any consequential or incidental damages arising from the breach of these warranties or any other warranty, whether express, implied, or statutory. Some states do not allow the exclusion or limitation of incidental or consequential damages, so the above limitation or exclusion may not apply to you. These warranties give you specific legal rights, and you may also have other rights which vary from state to state.

Any warranty that may be implied in connection with your purchase or use of the product, including any warranty of *merchantability* or any warranty *fit for a particular purpose* is limited to the duration of these warranties, and only extends to five years in duration for the parts described in the section related to the five year limited warranty above. Some states do not allow limitations on how long an implied warranty lasts, so the above limitations may not apply to you.

- The warranties only apply to the original purchaser and are non-transferable.
- The second, third, and five year warranties cover products installed and used for normal residential or designated marine use only.
- The warranties apply to units operated outside only if designed for outdoor use by model and serial number.
- U-Line Commercial products are covered by the one year and 5 year limited warranties and are not eligible for the second and third year limited warranties.
- Replacement water filters, light bulbs, and other consumable parts are not covered by these warranties.
- The start of U-Line's obligation is limited to four years after the shipment date from U-Line.
- In-home instruction on how to use your product is not covered by these warranties.
- Food, beverage, and medicine loss are not covered by these warranties.
- If the product is located in an area where U-Line factory authorized service is not available, you may be responsible for a trip charge or you may be required to bring the product to a U-Line factory authorized service location at your own cost and expense.
- Units purchased after use as floor displays, and/or certified reconditioned units, are covered by the limited one year warranty only and no coverage is provided for cosmetic defects.
- Signal issues related to Wi-Fi connectivity are not covered by these warranties.

For parts and service assistance, or to find U-Line factory authorized service near you, contact U-Line:
8900 N. 55th Street, Milwaukee, WI 53223 • u-line.com • onlineservice@u-line.com • +1.414.354.0300