

**SAMSUNG**

# User guide

**MX-ST40F**

Thank you for purchasing this Samsung product.

To receive more complete service, please register your product at [www.samsung.com](http://www.samsung.com)









# SAFETY INFORMATION

## SAFETY WARNINGS

TO REDUCE THE RISK OF ELECTRIC SHOCK, DO NOT REMOVE THE COVER (OR BACK).

NO USER-SERVICEABLE PARTS ARE INSIDE. REFER SERVICING TO QUALIFIED SERVICE PERSONNEL.

Refer to the table below for an explanation of symbols which may be on your Samsung product.

	<p style="text-align: center;"><b>CAUTION</b> <b>RISK OF ELECTRIC SHOCK</b> <b>DO NOT OPEN</b></p>	
	<p>This symbol indicates that high voltage is present inside. It is dangerous to make any kind of contact with any internal part of this product.</p>	
	<p>This symbol indicates that this product comes with important literature concerning operation and maintenance.</p>	
	<p>Class II product: This symbol indicates that a safety connection to electrical earth (ground) is not required. If this symbol is not present on a product with a power cord, the product MUST have a reliable connection to protective earth (ground).</p>	
	<p>AC voltage: Rated voltage marked with this symbol is AC voltage.</p>	
	<p>DC voltage: Rated voltage marked with this symbol is DC voltage.</p>	
	<p>Caution. Consult Instructions for use: This symbol instructs the user to consult the user manual for further safety related information.</p>	

## WARNING

- To reduce the risk of fire or electric shock, do not expose this appliance to rain or moisture.
- This product contains chemicals known to the State of California to cause cancer and birth defects or other reproductive harm.
- The battery (battery or batteries or battery pack) shall not be exposed to excessive heat such as sunshine, fire or the like.
- Do not use liquid fumigators containing chemicals, such as mosquito repellent or air freshener, around the product. If steam comes in contact with the product surface or enters the product, it may cause stains or malfunction.

## CAUTION

- Do not expose this apparatus to dripping or splashing. Do not put objects filled with liquids, such as vases, on the apparatus.
- To turn this apparatus off completely, you must pull the power plug out of the wall socket. Consequently, the power plug must be easily and readily accessible at all times.

## FCC NOTE (for U.S.A.):

### FCC Supplier's Declaration of Conformity

#### Responsible Party - U.S. Contact Information:

Samsung Electronics America, Inc. 700 Sylvan Avenue, Englewood Cliffs, NJ 07632

Phone: 1-800-SAMSUNG (726-7864)

#### FCC Compliance Statement:

This device complies with Part 15 of the FCC Rules. Operation is subject to the following two conditions:

- (1) This device may not cause harmful

interference, and (2) this device must accept any interference received, including interference that may cause undesired operation.

**FCC Caution:**

- Any changes or modifications not expressly approved by the party responsible for compliance could void the user’s authority to operate this equipment.
- This product satisfies FCC regulations when shielded cables and connectors are used to connect the unit to other equipment. To prevent electromagnetic interference with electric appliances, such as radios and televisions, use shielded cables and connectors for connections.

**Class B FCC Statement**

This equipment has been tested and found to comply with the limits for a Class B digital device, pursuant to Part 15 of the FCC Rules. These limits are designed to provide reasonable protection against harmful interference in a residential installation. This equipment generates, uses and can radiate radio frequency energy and, if not installed and used in accordance with the instructions, may cause harmful interference to radio communications. However, there is no guarantee that interference will not occur in a particular installation. If this equipment does cause harmful interference to radio or television reception, which can be determined by turning the equipment off and on, the user is encouraged to try to correct the interference by one of the following measures:

- Reorienting or relocating the receiving antenna.
- Increasing the separation between the equipment and receiver.
- Connecting the equipment to an outlet that is on a different circuit than the radio or TV.
- Consulting the dealer or an experienced radio/TV technician for help.

**FCC Radiation Exposure Statement:**

This equipment complies with FCC radiation exposure limits set forth for an uncontrolled environment. This equipment should be installed and operated so there is at least 8 inches (20 cm) between the radiator and your body. This device and its antenna(s) must not be co-located or operated in conjunction with any other antenna or transmitter.

**CALIFORNIA USA ONLY (Applicable for networking models only.)**

This Perchlorate warning applies only to primary CR(Manganese Dioxide) Lithium coin cells in the product sold or distributed ONLY in California USA “Perchlorate Material - special handling may apply, See [www.dtsc.ca.gov/hazardouswaste/perchlorate](http://www.dtsc.ca.gov/hazardouswaste/perchlorate).” Dispose unwanted electronics through an approved recycler. To find the nearest recycling location, go to our website: [www.samsung.com/recycling](http://www.samsung.com/recycling) Or call, 1-800-SAMSUNG For battery recycling go to [call2recycle.org](http://call2recycle.org); or call 1-800-822-8837



**⚠ WARNING: Cancer and Reproductive Harm - [www.P65Warnings.ca.gov](http://www.P65Warnings.ca.gov).**

**Samsung products and recycling**

- Dispose unwanted electronics through an approved recycler. To find the nearest recycling location, go to our website: [www.samsung.com/recycling](http://www.samsung.com/recycling) Or call, 1-800-SAMSUNG.
- **WARNING!** Never dispose of batteries in a fire because they may explode. Do not disassemble, crush, puncture, heat, burn or reuse batteries. For more information, visit [call2recycle.org](http://call2recycle.org) or call 1-800-822-8837. Alternatively, visit: [www.samsung.com/recycling](http://www.samsung.com/recycling) or call 1-800-SAMSUNG.

## Important Safety Instructions

Read these operating instructions carefully before using the unit. Follow all the safety instructions listed below. Keep these operating instructions handy for future reference.

1. Read these instructions.
2. Keep these Instructions.
3. Heed all warnings.
4. Follow all instructions.
5. Clean only with dry cloth.
6. Do not block any ventilation openings. Install in accordance with the manufacturer's instructions.
7. Do not install near any heat sources such as radiators, heat registers, stoves, or other apparatus (including amplifiers) that produce heat.
8. Do not defeat the safety purpose of the polarized or grounding-type plug. A polarized plug has two blades with one wider than the other. A grounding type plug has two blades and a third grounding prong. The wide blade or the third prong are provided for your safety. If the provided plug does not fit into your outlet, consult an electrician for replacement of the obsolete outlet.
9. Protect the power cord from being walked on or pinched particularly at plugs, convenience receptacles, and the point where they exit from the apparatus.
10. Only use attachments/accessories specified by the manufacturer.
11. Use only with the cart, stand, tripod, bracket, or table specified by the manufacturer, or sold with the apparatus. When a cart is used, use caution when moving the cart/apparatus combination to avoid injury from tip-over.
12. Unplug this apparatus during lightning storms or when unused for long periods of time.



13. Refer all servicing to qualified service personnel. Servicing is required when the apparatus has been damaged in any way, such as power-supply cord or plug is damaged, liquid has been spilled or objects have fallen into the apparatus, the apparatus has been exposed to rain or moisture, does not operate normally, or has been dropped.

## To avoid deterioration of water resistance

Check the following and use the unit correctly.

- Deformation or damage from dropping the unit or subjecting it to mechanical shock may cause deterioration of the water resistance.
- This unit does not have a design that is resistant to water pressure. Use of the unit in a location where high water pressure is applied, such as in the shower, may cause a malfunction.
- Do not pour high-temperature water or blow hot air from a hair dryer or any other appliance on the unit directly. Also never use the unit in a place subject to high temperatures, such as in a sauna or near a heat source.
- Handle the cap with care. Port cover and AC plug cover play a very important role in maintenance of the water resistance. When using the unit, make sure that the cap is closed completely. When closing the cap, be careful not to allow foreign objects inside. If the cap is not closed completely the water resistance may deteriorate and may cause a malfunction of the unit as a result of water entering the unit.
- IPX4 cannot be met when any JACK or AC power is plugged in.
- Do not lay down the product horizontally to ensure it remains water resistant.



- The Sound Tower provides durability by IPX4.

Protection against solids	IP		Protection against water
	0	4	
No requirements	X	X	No requirements
No protection	0	0	No protection
Solids > 50 mm	1	1	Vertically falling water
Solids > 12 mm	2	2	Vertically water-enclosure tilted 15°
Solids > 2.5 mm	3	3	Sprayed water 60° from vertical
Solids > 1.0 mm	4	4	Splashed water from all directions
Dust Protected	5	5	Hosing jets from all directions
Dust tight	6	6	Strong hosing jets from all directions
-		7	Temporary Immersion: 1m for 30 minutes
-		8	Immersion: manufacture defined depth and time

# PRECAUTIONS

1. Ensure that the AC power supply in your house complies with the power requirements listed on the identification sticker located on the bottom of your product. Make sure the ventilation slots are not covered. Do not place the unit on amplifiers or other equipment which may become hot. This unit is designed for continuous use. To fully turn off the unit, disconnect the AC plug from the wall outlet. Unplug the unit if you intend to leave it unused for a long period of time.
2. During thunderstorms, disconnect the AC plug from the wall outlet. Voltage peaks due to lightning could damage the unit.
3. Do not expose the unit to direct sunlight or other heat sources. This could lead to overheating and cause the unit to malfunction.
4. Protect the product from moisture (i.e. vases), and excess heat (e.g. a fireplace) or equipment creating strong magnetic or electric fields. Unplug the power cable from the AC wall socket if the unit malfunctions. Your product is not intended for industrial use. It is for personal use only. Condensation may occur if your product has been stored in cold temperatures. If transporting the unit during the winter, wait approximately 2 hours or until the unit has reached room temperature before using.
5. The battery used with this product contains chemicals that are harmful to the environment. Do not dispose of the battery in the general household trash. Do not expose the battery to excess heat, direct sunlight, or fire. Do not short circuit, disassemble, or overheat the battery.  
**CAUTION:** Danger of explosion if the battery is replaced incorrectly. Replace only with the same or equivalent type.

## Others

- As the battery is manufactured only for this product, do not use the battery for other electronic appliances or other purposes.
- When discarding a dead battery, put it into a battery collection box for recycling.
- To protect the battery, the battery cannot be charged when the temperature is lower than 3 °C or higher than 42 °C.
- When the battery level is low, recharge it. If the level of the battery remains low for a long period of time, it can cause the performance of the battery to degrade.
- Do not apply heat to the battery and do not put the battery in a fire.
- To protect the battery, the Sound Tower may not operate when the temperature is lower than -17 °C or higher than 57 °C.

# CONTENTS

<b>01</b>	<b>CHECKING THE COMPONENTS</b>	<b>1</b>
<b>02</b>	<b>PRODUCT OVERVIEW</b>	<b>2</b>
	Top Panel of the Sound Tower	2
	Rear Panel of the Sound Tower	4
<b>03</b>	<b>CONNECTING THE SOUND TOWER</b>	<b>7</b>
	Connecting Electrical Power	7
	How to use Audio Group	8
<b>04</b>	<b>CONNECTING AN EXTERNAL DEVICE</b>	<b>14</b>
	Connecting using an Analog Audio (AUX) Cable	14
	Connecting a mobile device via Bluetooth	15
<b>05</b>	<b>CONNECTING A USB STORAGE DEVICE</b>	<b>18</b>
	Software Update	19
	Connecting an External Microphone	20
	Connecting an External Guitar	21
	How to use Sound Mode	22
	How to use the DJ Effect	22
<b>06</b>	<b>USING THE SAMSUNG SOUND TOWER APP</b>	<b>23</b>
	Install Samsung Sound Tower App	23
	Launching the Samsung Sound Tower App	23

<b>07</b>	<b>TROUBLESHOOTING</b>	<b>24</b>
<b>08</b>	<b>LICENSE</b>	<b>25</b>
<b>09</b>	<b>OPEN SOURCE LICENSE NOTICE</b>	<b>26</b>
<b>10</b>	<b>IMPORTANT NOTES ABOUT SERVICE</b>	<b>26</b>
<b>11</b>	<b>SPECIFICATIONS AND GUIDE</b>	<b>27</b>
	Specifications	_____ 27

# 01 CHECKING THE COMPONENTS



**Sound Tower Main Unit**



**Power Cord (AH81-15587A)**

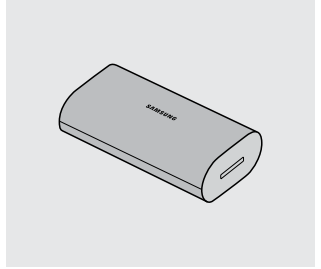

**Battery (AH81-18495A)**

- For more information about the power supply and power consumption, refer to the label attached to the product. (Label: Rear of the Sound Tower Main Unit)
- To purchase additional components or optional cables, contact a Samsung Service Center or Samsung Customer Care.
- When moving the product, do not drag or pull the product from the ground. Lift the product when moving the product.
- Design and specifications are subject to change without prior notice.

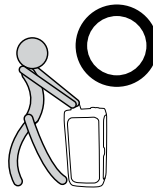

# 02 PRODUCT OVERVIEW

## Top Panel of the Sound Tower

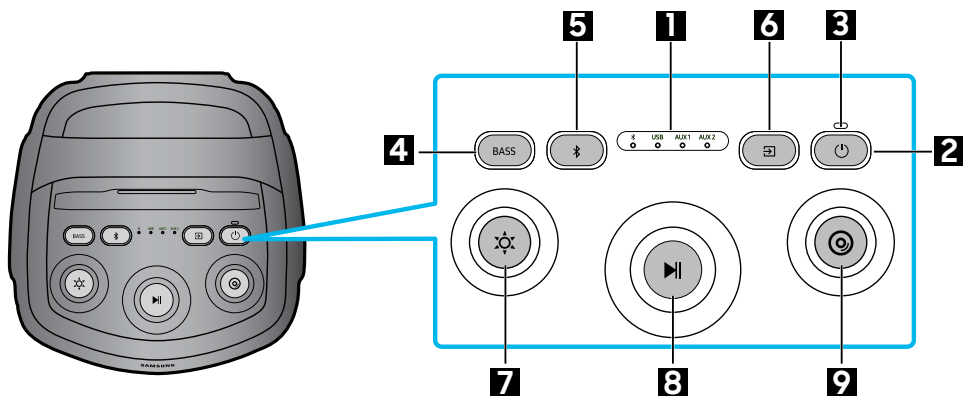



<b>1</b>	<b>LED Indicator</b>	Displays operating messages or current source of the Sound Tower system. The information sources represented by each LED are as follows: * (Bluetooth) <b>USB</b> (USB) <b>AUX1</b> (AUX1) <b>AUX2</b> (AUX2)
<b>2</b>	<b>Power</b>	Turns the Sound Tower on and off.
<b>3</b>	<b>Charge LED</b>	Displaying battery level information of Sound Tower.
<b>4</b>	<b>BASS</b>	Press the <b>BASS</b> button to change the bass mode.
<b>5</b>	<b>Bluetooth PAIRING</b>	Press and hold the * button to enter Bluetooth Pairing mode, and the * LED blinks blue.
<b>6</b>	<b>Source</b>	Press to select a source connected to the Sound Tower.
<b>7</b>	<b>Light</b>	Press the ☀ ( <b>Light</b> ) button and the white light flashes, then rotate the button to switch between different Mood presets. <ul style="list-style-type: none"> <li>• Order: Festival → Energetic → Delight → Chill → Focus → Sports → Off → Festival → Energetic → ...</li> </ul>

<p><b>8</b></p>	<p><b>Play/Pause</b></p>	<ul style="list-style-type: none"> <li>• <b>Play/Pause</b> Press the ▷⏸ button to pause a music temporarily. When you press the button again, the music plays. Double press Play/Pause skips music to the next one. Press 3 times to switch to the previous one.</li> </ul>
<p><b>9</b></p>	<p><b>DJ</b></p>	<p>This button lets you Play a sampler (DJ audio effect) . Sampler (DJ audio effect) changes once rotate a jog (12 samplers)</p> <ul style="list-style-type: none"> <li>• Order: Air Horn→ Whistle → Crowd Cheer→Jeering→ Siren → Clap→rewind → Scratch → "No Way!" → "Are you ready" → "3,2,1"→ "Ok, Let's Go"→Air Horn→...</li> <li>• Play a sampler whenever change to notify what sampler is selected</li> </ul>

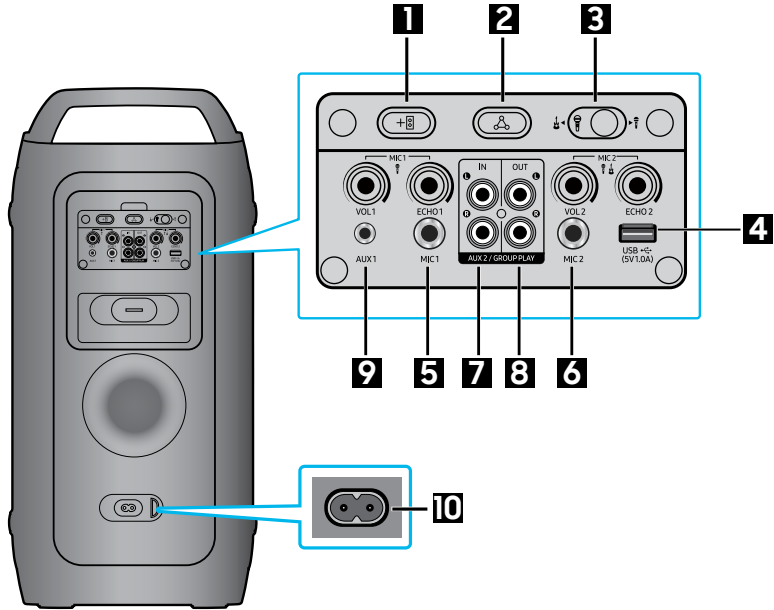
# Rear Panel of the Sound Tower



<b>1</b>	<b>ADD STEREO</b>	Press the <b>ADD STEREO</b> button to connect to another same model Sound Tower wirelessly.
<b>2</b>	<b>GROUP PLAY</b>	Press the <b>GROUP PLAY</b> button to connect up to ten Sound Tower systems wirelessly.
<b>3</b>	<b>MIC2/GUITAR</b>	Toggle the switch to <b>MIC2</b> or <b>GUITAR</b> input source.
<b>4</b>	<b>USB</b>	Connect a USB device to the <b>USB</b> ports on the main unit. If you connect your cell phone to the <b>USB</b> port, you can charge it. <ul style="list-style-type: none"> <li>• Press the  (<b>Source</b>) button to select <b>USB</b>.</li> </ul>
<b>5</b>	<b>MIC1</b>	Connect your microphone to the <b>MIC1</b> jack.
<b>6</b>	<b>MIC2</b>	Connect your microphone or guitar to the <b>MIC2</b> jack.

7	AUX2/GROUP PLAY IN Terminals	<p>Use an Audio Cable (not supplied) to connect <b>AUX2 (IN)</b> terminals on the main unit to Audio Out on an external analogue output device.</p> <ul style="list-style-type: none"> <li>• Be sure to match connector colours.</li> <li>• If the external analogue output device has only one Audio Out jack, connect either left or right.</li> <li>• Press the  (<b>Source</b>) button to select <b>AUX2</b>.</li> <li>• If the product is in <b>AUX2</b> mode with no playback and no command input for more than 20 minutes, the system will turn off.</li> <li>• If the product is in <b>AUX2</b> mode with playback for more than 8 hours and no command input, the system will turn off.</li> </ul>
8	GROUP PLAY OUT Terminals	<p>Use an Audio Cable (not supplied) to connect <b>GROUP PLAY (OUT)</b> terminals on the main unit to Audio In on an external analog output device.</p>
9	AUX1	<p>Use an Audio (AUX) Cable (not supplied) to connect <b>AUX1</b> jack on the main unit to Audio Out on an external device.</p> <ul style="list-style-type: none"> <li>• If the product is in <b>AUX1</b> mode with no playback and no command input for more than 20 minutes, the system will turn off.</li> <li>• If the product is in <b>AUX1</b> mode with playback for more than 8 hours and no command input, the system will turn off.</li> </ul>
10	Power	<p>Connect the power cord to the <b>Power</b> jack and connect the other end of the power cord to a wall socket to supply electrical power to the Sound Tower.</p>

Charge LED State of the Sound Tower:

Charging state	Charge LED
not charging and 100% ~ 31% power	Green
not charging and 30% ~ 11% power	Orange
not charging and 10% ~ 5% power	Red
Charging and full charge	Blue
Charging and 99% ~ 31% power	Green Blink
Charging and 30% ~ 11% power	Orange Blink
Charging and 10% ~ 5% power	Red Blink

※ Auto power down if battery 5%.

In DC mode shutdown, the entire system power will be turned off.

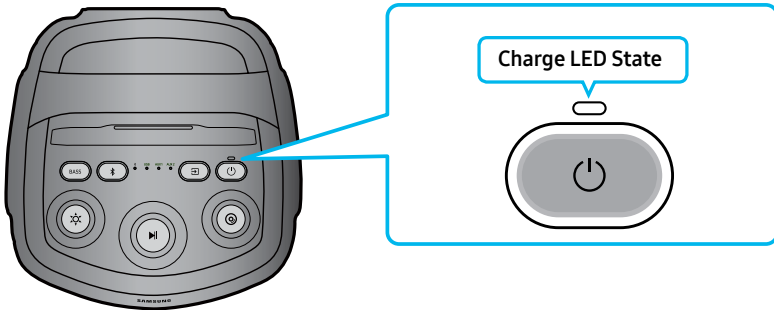

# 03 CONNECTING THE SOUND TOWER

## Connecting Electrical Power

Use the power cord to connect the Sound Tower to an electrical outlet in the following order: Connect the power cord to the Sound Tower and then to a wall socket.

See the illustrations below.

- **Before first use, please charge power to wake up the battery.**
- When the AC cord is pressed in, the built-in battery will be charged automatically until the battery is fully charged. The LED indicator on the top panel will show the current charging state. (refer to page ENG - 6)
- When you unplug the set to run on battery, the volume level drops dramatically.
- For more information about the required electrical power and power consumption, refer to the label attached to the product. (Label: Rear of the Sound Tower)

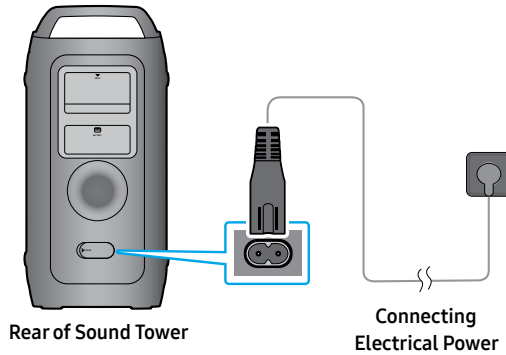

# How to use Audio Group

You can connect multiple audio systems in a group to create a party environment and produce higher sound output. Set one Sound Tower as the HOST and any music played on it will be shared among any other Sound Tower systems in the Audio group.

## Connecting the wired Group Play mode

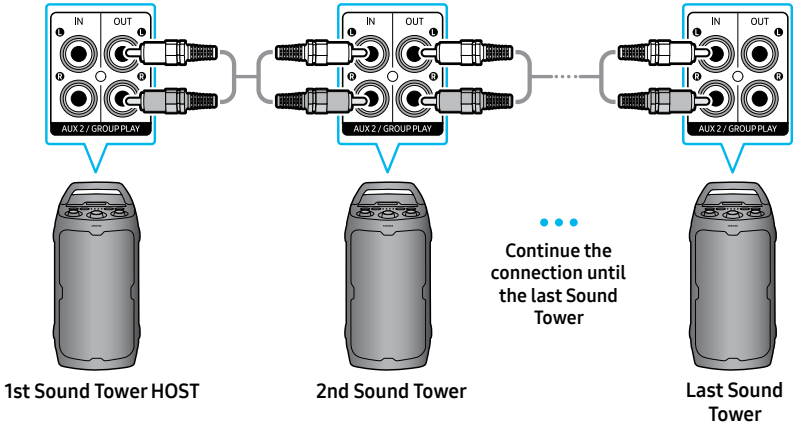

Set up Group Play by connecting all the systems using audio cables (not supplied). Use the  (Source) button to change the source to **AUX2** for every Sound Tower system except the 1st (or HOST) Sound Tower system.

Connect the RCA cable to the **AUX2 OUT** on the HOST and **AUX2 IN** on the SUB as shown by using the RCA cable (not supplied).

### NOTES

- The 1st Sound Tower HOST can play music from any source.
- Depending on the length or characteristics of the cable, there may be a difference in operating distance.

## Connecting the wireless Group Play mode

To use Wireless Group Play, you can use either the **Physical Buttons** located on the back of the device or in **Samsung Sound Tower** app.

You can connect up to ten Sound Tower systems with the wireless Group Play function.

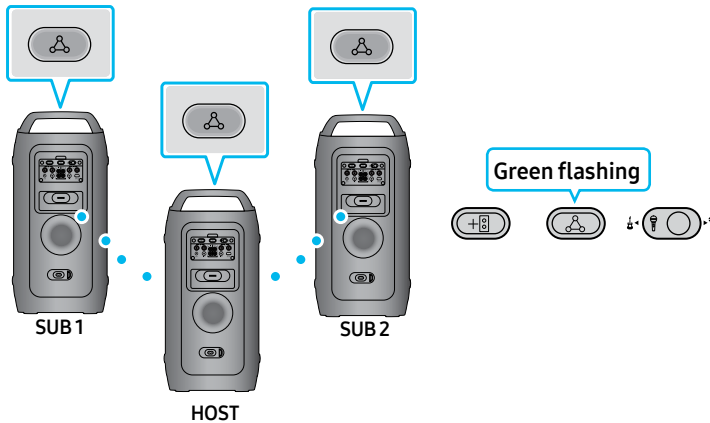

### Using Physical Buttons:

#### 1. Connect the **HOST** System:

Press the **GROUP PLAY** button on the **HOST** Sound Tower system.

After the **GROUP PLAY** LED slowly blinks for 10 seconds, the **GROUP PLAY** LED will blink rapidly for 30 seconds.

#### 2. Connect the First Sub System (SUB 1):

Press the **GROUP PLAY** button on the second Sound Tower system (SUB 1).

The **GROUP PLAY** LED will start blinking.

Once connected to the **HOST**, both the **GROUP PLAY** LEDs on SUB 1 and the **HOST** will stop blinking and remain lit.

#### 3. Connect the Second Sub System (SUB 2):

Press the **GROUP PLAY** button on the third Sound Tower system (SUB 2).

A tone prompt will play, indicating that the **GROUP PLAY** button on the system has stopped blinking.

#### 4. Add Additional Systems:

If you want to add more Sound Tower systems, repeat step 3 for each additional unit.

#### 5. Play Music:

Play music on the **HOST** Sound Tower system.

Sound will output from all connected systems simultaneously.

### Using the Samsung Sound Tower App:

#### 1. Download & Open the Samsung Sound Tower app on your smartphone or tablet.

#### 2. Connect Sound Tower via Bluetooth.

3. Navigate to the Group Play settings.
4. Toggle the switch to turn Wireless Group Play on or off.

### How to know which is HOST & which is SUB:

HOST - Shows "Bluetooth Button ✖ LED Light On" & Bluetooth small indicator on.

SUB - Shows only Bluetooth small indicator on. No light on Bluetooth button ✖.

### NOTES

- In Group play mode, "HOST" Sound Tower can connect to the Samsung TV. After the connection is successful, the Group play mode automatically exits.
- The wireless Group Play connection is available for MX-ST50F/MX-ST40F.
- Environmental conditions or other factors with connected devices may have effect on playback quality.
- If the red LED is on the **GROUP PLAY** button, an error has occurred in the wireless Group Play connection. Try turning off and then turn on, then follow the steps from 1 to 3.
- The **ADD STEREO** button and ✖ **PAIRING** button on the SUB Sound Tower systems are not available while in wireless Group Play mode.
- The **ADD STEREO** button on the HOST Sound Tower system is not available while in wireless Group Play mode.
- Long press "**GROUP PLAY**" in Bluetooth Source state to enter Group mode as "HOST". All SUB units must be connected one by one. For example, after HOST is connected, press **GROUP PLAY** button on SUB 1 to connect, and after SUB 1 is connected, you should connect SUB 2 and SUB 3 one by one sequentially.
- While using Group Play, currently connected Bluetooth devices are disconnected and Bluetooth connection is disabled.
- Bluetooth devices can search and connect with the HOST Sound Tower only.
- When in Group Play mode, the SUB cannot connect to a Bluetooth device.
- If the Sound Tower is powered off and then turned back on, or if a source other than Bluetooth is selected on a SUB unit while in Group Play mode, the Group Play connection will be disconnected.

### Disconnecting the wireless Group Play mode

1. Press and hold the **GROUP PLAY** button over 5 seconds (HOST or SUB) after Group Play is connected or press the **GROUP PLAY** button (HOST or SUB) before Group Play is connected.
  - Tone prompt instead and the LED above the **GROUP PLAY** button is off.
2. If you select any source other than **Bluetooth** on the SUB units or turn off the HOST Sound Tower, the Group Play mode is disconnected.
  - If the disconnection is made from the HOST Sound Tower, Group Play is disconnected.

## Wireless Group Play connections

### 1. Connected to Smartphone:

- Connect smartphone via Bluetooth to HOST Sound Tower, then connect other SUB Sound Towers wireless Group play to HOST.
  - Play/Pause, audio skip, volume increase/decrease buttons on set only works on HOST Sound Tower.
  - SUB Sound Towers volume can be adjusted separately on the set.

### 2. Connected to Mic/Guitar, USB, AUX:

- **Mic/Guitar:** When microphone or Guitar is connected on MIC 1 or MIC 2 and Group play LEDs are paired, sound only produces from the Sound Tower that it is plugged in.
- **USB:** Wireless Stereo connection stay connected but sound only produces from the HOST Sound Tower where USB is connected.
- **AUX:** When plugged on AUX 1 and Source on AUX 1, Sound only produces from HOST Sound Tower.

## LED Indications

LED	STATE	Description
Green	Blink	Waiting for a wireless Group Play connection.
	Solid	The wireless Group Play connection was successful.
Red	Solid	There is an error with the wireless Group Play connection.

## NOTE

- In wireless connection, Playback quality can be unstable depending on Bluetooth environment. For better play, please keep the device in wired Group Play mode.
- The first Bluetooth connection should be within 1m.
- The lighting colors between MAIN Sound Tower and SUB Sound Tower may vary.

## Using wireless ADD Stereo Group mode

To use Wireless ADD Stereo, you can use either the **Physical Buttons** located on the back of the device or in **Samsung Sound Tower** app.

Connect two Sound Tower and use them with your Smartphone or Samsung TV to enjoy stereo sound.

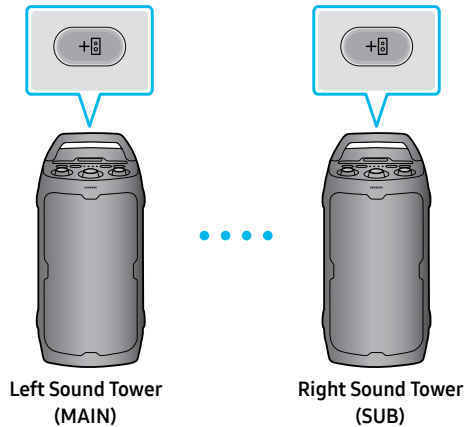

### Using Physical Buttons:

1. Press the **ADD STEREO** button on the left Sound Tower system. The LED blinks on the **ADD STEREO** button.
2. Press the **ADD STEREO** button on the right Sound Tower system. The LED blinks on the **ADD STEREO** button.
3. When the connection is made, tone prompt. Back panel ADD LED Green Indicator Steady on.
  - The MAIN Sound Tower system outputs left channel sound and the SUB Sound Tower system outputs right channel sound. Press the **ADD STEREO** button on the MAIN or SUB Sound Tower to change the sound channel of the Sound Tower.
4. Sound is output from both Sound Tower.

### Using the Samsung Sound Tower App:

1. Download & Open the Samsung Sound Tower app on your smartphone or tablet.
2. Connect Sound Tower via Bluetooth.
3. Navigate to the Stereo settings.
4. Toggle the switch to turn Wireless ADD Stereo on or off.

### How to know which is HOST & which is SUB:

HOST - Shows "Bluetooth Button ✂ LED Light On" & Bluetooth small indicator on.

SUB - Shows only Bluetooth small indicator on. No light on Bluetooth button ✂.

### NOTES

- To use the Stereo Group mode, both Sound Tower systems must be the same model.
- Environmental conditions or other factors with connected devices may have effect on playback

quality.

- If the red LED is on the **ADD STEREO**, an error has occurred in the Stereo Group connection. Turn off both Sound Tower systems, unplug them from the power source if they are connected. Then turn on & try Step 1 to 3 again. If not plugged replug them. Turn off both Sound Tower systems. Then turn on & try Step 1 to 3 again.
- **Bluetooth PAIRING** and **GROUP PLAY** on the SUB Sound Tower systems are disabled while in Stereo Group mode.
- The **GROUP PLAY** button on the MAIN Sound Tower system is not available while in Stereo Group mode.
- When ADD Stereo is connected wirelessly to Smartphone via Bluetooth: Play/Pause button on set only works with HOST Sound Tower not SUB Sound Tower.
- In mode other than “**Bluetooth**” (ex. **USB, AUX** mode), music is played only in MAIN Sound Tower and music is not played in SUB Sound Tower.
- If you try to connect a Bluetooth device while Stereo Group is connecting, the Stereo Group mode may fail.

### Wireless Stereo connection:

#### 1. Connected to Smartphone:

- Wireless Stereo can be connected to same model Sound Towers.
- Play/Pause, audio skip, previous audio functions are applicable to HOST Sound Tower.
- Play/Pause is the only function supported on SUB Sound Tower.

#### 2. Connected to Mic/Guitar, USB, AUX:

- **Mic/Guitar:** Wireless Stereo connects solid green light but sound produces only on the unit that Mic/Guitar is connected to.
- **USB:** Wireless Stereo connection stay connected but sound only produces from the HOST Sound Tower where USB is connected.
- **AUX:** When plugged on AUX 1 and Source on AUX 1, Sound only produces from HOST Sound Tower. Only volume level can be adjusted on SUB Sound Tower.

### Terminate the Stereo Group mode

Press the **ADD STEREO** button (MAIN or SUB) for at least 5 seconds while the Stereo Group is connected.

- Tone prompt and the LED above the **ADD STEREO** button is off.

### LED Indications

LED	STATE	Description
Green	Blink	Waiting for a Stereo Group connection.
	Solid	The Stereo Group connection is successful.
Red	Solid	There is an error with the Stereo Group connection.

# 04 CONNECTING AN EXTERNAL DEVICE

Connect to an external device via a wired or wireless network to play the external device's sound through the Sound Tower.

## Connecting using an Analog Audio (AUX) Cable

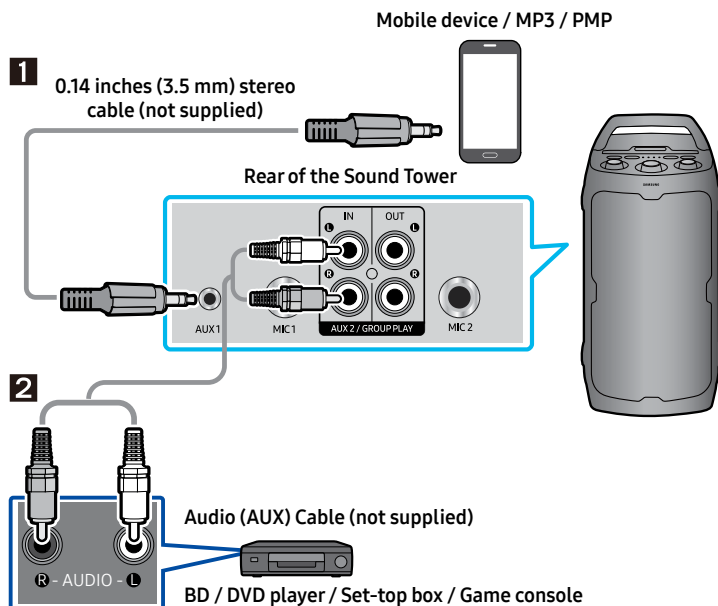

### 1 3.5 mm stereo Cable (AUX1)

1. Connect **AUX1** jack on the main unit to the AUDIO OUT jack of the Source Device using a 3.5 mm stereo cable.
2. Select "**AUX1**" mode by pressing the  (**Source**) button on the top panel.

### 2 Audio Cable (AUX2)

1. Connect **AUX2 (IN)** terminals on the main unit to the AUDIO OUT terminals of the Source Device using an audio cable.
2. Select "**AUX2**" mode by pressing the  (**Source**) button on the top panel.

# Connecting a mobile device via Bluetooth

When a mobile device is connected using Bluetooth, you can hear stereo sound without the hassle of cabling.

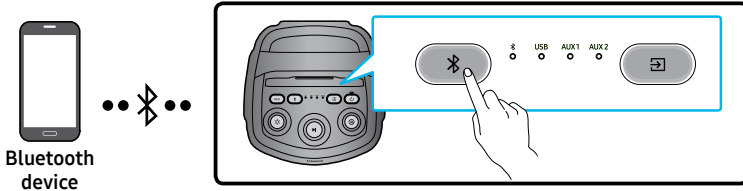

\* In battery mode, when the Sound Tower is power off, Bluetooth connection and the Sound Tower APP are not available.

## The initial connection

1. Press and hold the **PAIRING** button on the top panel for more than 5 seconds to enter the "Bluetooth PAIRING" mode.
2. On your device, select "[AV] Sound Tower 40F" from the list that appears.
  - After the device is connected and the Bluetooth light on the top panel is steady on.
3. Play music files from the device connected via Bluetooth through the Sound Tower.

## If the device fails to connect

- Sound Tower will play prompt sound when Bluetooth disconnect.
- If a previously connected Sound Tower listing (e.g. "[AV] Sound Tower 40F") appears in the list, delete it.
- Then repeat steps 1 and 2.

## What is the difference between Bluetooth READY and Bluetooth PAIRING?

- **Bluetooth READY:** In this mode, you can use the previously connected TV or mobile device to connect to Sound Tower.
- **Bluetooth PAIRING:** In this mode, you can connect a new device to the Sound Tower. (hold down the **PAIRING** button on the panel for more than 5 seconds to enter the **PAIRING** state.)

## **Bluetooth Multi connection**

Sound Tower supports up-to two simultaneous Bluetooth device connections. Sound Tower can play music through one of the connected Bluetooth devices without disconnecting the second device.

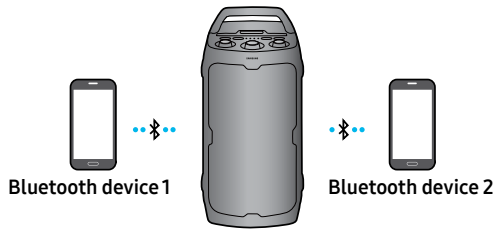

1. Connect Sound Tower to the first device and the second device respectively for the first time. (See ENG - 15)
2. Music can be played on only one of the two connected devices, and when the music is played on the other device, the music on the playing device is paused.

### **NOTES**

- If you want to connect Sound Tower to a third device, you can disconnect Sound Tower from one of the two currently connected devices and then connect Sound Tower to the third device. (Multi connection would not work on Samsung TVs.)
- With the Sound Tower and two devices currently connected, when pairing to a new Bluetooth device, the devices currently connected should be disconnected.
- You can connect to two Bluetooth devices at the same time.
- Environmental conditions or other factors with connected devices may have effect on playback quality.
- The Sound Tower automatically turns off after 18 minutes with no command input in the ready state.
- The Sound Tower may not perform Bluetooth search or connection correctly under the following circumstances:
  - If there is a strong electrical field around the Sound Tower.
  - If several Bluetooth devices are simultaneously paired with the Sound Tower.
  - If the Bluetooth device is turned off, not in place, or malfunctions.
- Electronic devices may cause radio interference. Devices that generate electromagnetic waves must be kept away from the Sound Tower main unit - e.g., microwaves, wireless LAN devices, etc.

- Bluetooth Multi connection may not be supported depending on the connected device's specifications.
- Removable/detachable Bluetooth devices such as Dongles, Adapters, etc. used on Smartphones, laptops, TVs, etc. do not support Bluetooth Multi connection.
- After Bluetooth Multi connection pairing, there may be a slight delay before music starts playing depending on the Bluetooth devices.
- If you move too far out of range from the Sound Tower without first disconnecting your Bluetooth device, it may take a few minutes to connect other Bluetooth devices. If you turn the Sound Tower off and back on, you can connect other Bluetooth devices without waiting.

## LED Indications

LED	STATE	Description
Blue	Fast Blink	Bluetooth PAIRING mode
	Blink	Bluetooth READY mode
	Solid	A Bluetooth device is connected.

## Using Bluetooth Power On

When the Sound Tower is turned off, you can connect your smart device via a Bluetooth connection to turn it on. Battery status cannot use Bluetooth power on.

1. Press and hold the **BASS** button on the top panel to set the Bluetooth Power On function on. Lighting bar will be blink white once.
  - Only works when Sound Tower is plugged into power - cannot wake up Sound Tower with Bluetooth when unplugged from outlet.
2. When the Sound Tower is off, connect your smart device via Bluetooth. (For information on Bluetooth connections, refer to your smart device's manual.)
3. When the connection is complete, the Sound Tower turns itself on automatically in Bluetooth mode.
  - Select the desired music to play from your smart device.

## NOTE

- Each time you press and hold the **BASS** button for 5 seconds. LED lighting bar will be blink white once and status switched:

**BLUETOOTH POWER-ON → BLUETOOTH POWER-OFF**

# 05 CONNECTING A USB STORAGE DEVICE

You can play music files located on USB storage device through the Sound Tower.

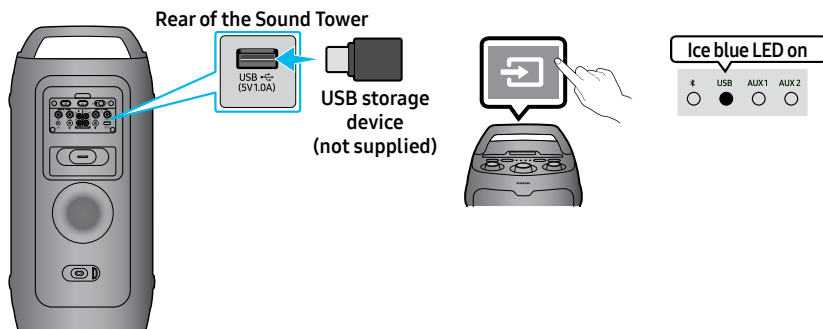

1. Connect a USB storage device to the USB port on your Sound Tower.
2. Press the  (**Source**) button on the top panel and then select "USB".
3. The second **USB** indicator on the top panel is steady on.
4. Play music files from the USB storage device through the Sound Tower.
  - The Sound Tower automatically turns off (Auto Power Down) if USB device is not connected, playback stopped, or there is no input for more than 18 minutes.
  - Music skips when (Play/Pause) button is pressed twice on set. Press 3 times to switch to the previous song.

## NOTES

- This product only supports USB storage devices that are formatted in the FAT and FAT32 file system.
- A maximum of 2000 files can be played per USB storage device.
- A maximum of 200 folders can be read per USB storage device.

## Supported Audio Formats

Extension	CODEC	Sampling Rate	Bitrate
*.mp3	MPEG1 Layer2	32KHz ~ 48KHz	32Kbps ~ 320Kbps
	MPEG1 Layer3	32KHz ~ 48KHz	32Kbps ~ 320Kbps
	MPEG2 Layer3	16KHz ~ 24KHz	8Kbps ~ 160Kbps
	MPEG2.5 Layer3	8KHz ~ 12KHz	8Kbps ~ 160Kbps
*.wav	LPCM	32KHz ~ 192KHz	1,024Kbps ~ 9,216Kbps
*.aac	AAC-LC (MPEG2,/MPEG4)	32KHz ~ 48KHz	32Kbps ~ 320Kbps
*.flac	FLAC	32KHz ~ 192KHz	162Kbps ~ 8,100Kbps

### NOTES

- The above table shows supported sampling rates and bit rates. Files in formats that are not supported will not play.
- 32-bit data size is not supported.

## Software Update

### **Samsung may offer updates for the Sound Tower's system firmware in the future.**

If an update is offered, you can update the firmware by connecting a USB device with the firmware update stored on it to the **USB** port on your Sound Tower. For more information about how to download update files, go to the Samsung Electronics website at [www.samsung.com/us/support/](http://www.samsung.com/us/support/). Then, enter or select the model number of your Sound Tower, select the Software & Apps option, and then Downloads. Note that the option names can vary.

If the upgrade takes more than 10 minutes, it means the upgrade process is stuck. Please press and hold the Power button on the top panel for 10 seconds and wait 1 minute. Press the Power button again to start the device and operate it to re-upgrade via USB. Then, wait until the upgrade is complete. (Reset upgrade only supports FAT format)

Software upgrades can also be performed by using the APP.

# Connecting an External Microphone

You can output your voice from the system by connecting a dynamic microphone with a normal plug (not supplied).

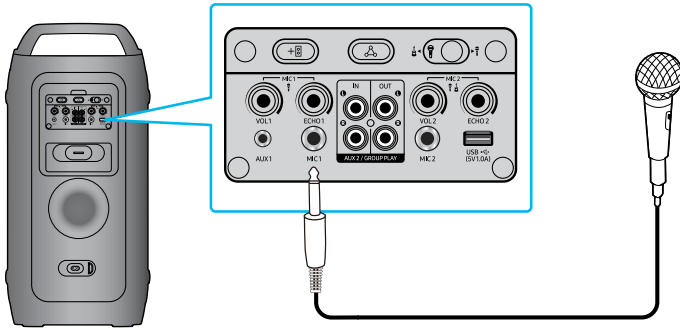

1. Turn the MIC LEVEL knob to MIN to reduce the microphone volume level.
2. Connect an optional microphone to the MIC jack on the unit.
3. Adjust the volume using the MIC “VOL” knob.
4. Adjust the Effect of the echo using the MIC “ECHO” knob.
5. Speak or sing into the connected microphone.

## NOTES

- When using the wireless Group Play or Stereo mode, the audio from the microphone connected to the Host or Sub system will be output only on Sound Tower that it is plugged in. In contrast, microphones connected to Sub systems will only be heard on their respective systems.
- When Sound Tower is in battery mode, the MIC sound level will be lower.
- Toggle the switch to MIC2 or GUITAR input source (Volume is lower compared on Microphone source).

# Connecting an External Guitar

You can output your voice from the system by connecting a Guitar with a normal plug (not supplied).

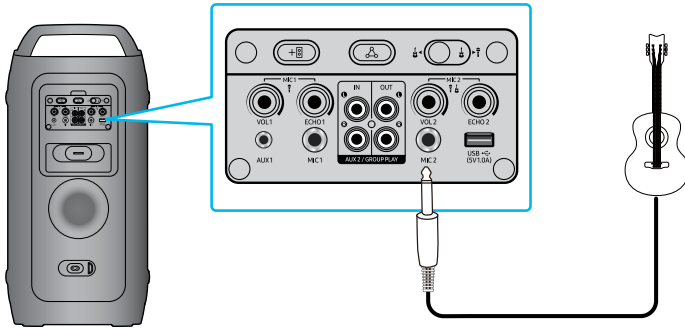

1. Turn the MIC LEVEL knob to MIN to reduce the Guitar volume level.
2. Connect an optional Guitar to the MIC 2 jack on the unit.
3. Adjust the volume using the MIC 2 "VOL" knob.
4. Play into the connected guitar.

## NOTES

- When using the wireless Group Play or Stereo mode, the audio from the guitar connected to the Host or Sub system will be output only on Sound Tower that it is plugged in. In contrast, Guitar connected to Sub systems will only be heard on their respective systems.
- When Sound Tower is in battery mode, the Guitar sound level will be lower.

## How to use Sound Mode

Your Sound Tower provides predefined equalizer settings that are optimized for particular music genres.

1. Press the **SOUND MODE** on the APP.
2. Each time you change the **SOUND MODE**, the Sound Tower cycles through the available sound effects: **Standard, Wide, Stadium, Outdoor**.

### NOTES

- Default sound mode is **Standard**.
- When turned off, press and hold the  button on product for more than 5 seconds to turn on in the default Sound Mode setting.

## How to use the DJ Effect

The DJ Effect function lets you add DJ sound effects to your music. The level of each effect is adjustable.

- Users can slide in APP to change effect and value, and the range is between 0 and 3.

### NOTE

- When turned off, press and hold the  button on product for more than 5 seconds to turn on in the default DJ Effect setting.

# 06 USING THE SAMSUNG SOUND TOWER APP

## Install Samsung Sound Tower App

To control this product with your Smart Device and the Samsung Sound Tower app, download the Samsung Sound Tower App from the Google Play Store or Apple App Store, and install it on your Smart Device.

### NOTES

- The Samsung Sound Tower app is compatible with Android mobile phone devices running Android OS 6.0 or later.
- The Samsung Sound Tower app is compatible with Apple mobile devices running iOS 13.0 or later.

Market search: Samsung Sound Tower



## Launching the Samsung Sound Tower App

To launch and use the Samsung Sound Tower app, touch the Samsung Sound Tower icon on your smart device, and then follow the directions on the screen.



# 07 TROUBLESHOOTING

Refer to the table below if this product does not function properly. If the problem you are experiencing is not listed below or if the instructions below do not help, turn off the product, disconnect the power cord, and contact Samsung Electronics at 1-800-SAMSUNG (1-800-726-7864).

## **The unit will not turn on.**

- The battery may be fully discharged.  
Please connect the power plug and try to turn it on

## **A function does not work when the button is pressed.**

- After removing the power plug, turn off the Sound Tower. And insert power plug again, turn on the Sound Tower.
- Power cycle the external device and try again.
- If there is no signal, the Sound Tower automatically turns off after a certain period of time. Turn on the power.

## **Sound dropouts occur in Bluetooth mode.**

- See the Bluetooth connection sections on ENG - 15.

## **Sound is not produced.**

### **Is the volume set to minimum?**

- Adjust the Volume.

## **Stereo Group connection is not working.**

### **Is the system in wireless Group Play mode?**

- Disconnect the wireless Group Play mode and try Stereo Group connection again.

## **It cannot make a Bluetooth connection.**

### **Is the system connected to another system in wireless Group Play mode or Stereo Group mode?**

- Try Bluetooth connection again after disconnecting the wireless Group Play or Stereo Group connection.

### **Are the two Bluetooth devices already connected?**

- Try Bluetooth connection again after disconnecting other Bluetooth connections.

## **The PAIRING button is not working.**

### **Is the system in wireless Group Play mode or Stereo Group mode?**

- Try again after disconnecting the wireless Group Play or Stereo Group connection.

## **I want to switch the HOST system to the other in wireless Group Play or Stereo Group connection.**

- Long press Group button 5 seconds, and after it use Group LED to judge instead connect the others one by one.
- With Stereo Group mode, HOST is fixed.  
You can not change others as HOST.

---

**It cannot make a “Wireless/Wired Group/Add Stereo/Bluetooth” connection.**

---

**Test after Turn off/on Sound Tower.**

**Hard reset Sound Tower.**

**Is the distance between systems too far?**

- It is recommended to make a “Wireless/Wired Group/Add Stereo/Bluetooth” pairing within 3.3 ft (1 meter) from the system.
- The recommended operating distance between Sound Tower systems is closer than 32.8 ft (10 meters).

---

**Sound Tower not turning on when attempting to wake up via Bluetooth.**

---

- The Auto Bluetooth Turn-On feature is only functional when the unit is connected to a power source.

---

**Customer Reset does not work.**

---

- Customer Reset does not work in DC Mode. Please connect the AC cord to operate the Customer Reset.
- 

## 08 LICENSE

---

 **AURACAST**

 **Bluetooth®**

---

The Bluetooth® word mark and logos are registered trademarks owned by Bluetooth SIG, Inc. The Auracast™ word mark and logos are trademarks owned by the Bluetooth SIG. Any use of such marks by Samsung Electronics Co., Ltd. is under license. Other trademarks and trade names are those of their respective owners.

\* Group Play with Auracast™ controls each Sound Tower individually for ST40F and ST50F only. In wireless connection, playback quality may be unstable depending on Bluetooth® environments.

---

To send inquiries and requests for questions regarding open sources, contact Samsung Open Source (<http://opensource.samsung.com>)

---

# 09 OPEN SOURCE LICENSE NOTICE

To send inquiries and requests for questions regarding open sources, contact Samsung Open Source (<http://opensource.samsung.com>)



# 10 IMPORTANT NOTES ABOUT SERVICE

- Figures and illustrations in this User Manual are provided for reference only and may differ from actual product appearance.
- An administration fee may be charged if either:
  - a. An engineer is called out to your home at your request and there is no defect in the product.
  - b. You bring the unit to a repair center and there is no defect in the product.
- You will be advised of the amount of the administration fee before any work is done or a home visit is made.
- If you have a problem with this product, we strongly recommend you read the appropriate section of this manual, visit the Support page for your product at [www.samsung.com](http://www.samsung.com), or call Samsung Product Support (1-800-726-7864) to find an answer before you contact a service center for a repair.

# 11 SPECIFICATIONS AND GUIDE

## Specifications

Model Name	MX-ST40F
USB	5V/1.0A
Weight	28.06 lbs (12.73 kg)
Dimensions (W x H x D)	11.9×24.4×12.2 inches (303.0×620.0×310.0 mm)
Operating Temperature Range	+41 °F to +95 °F (+5 °C to +35 °C)
Operating Humidity Range	10 % ~ 75 %
Overall Power Consumption	40 W
Battery Type	Lithium-ion 33.48 Wh
Battery play time	up to 12 hrs
Battery charge time	<3.5 hrs

Li-ion Rechargeable Battery	Battery Model	B3672CMS_FSC, 21NR22/71
	Nominal Voltage	7.2 V 
	Rated Capacity	4650 mAh, 33.48 Wh
	Limited Charge Voltage	8.3 V 
	Typical Capacity	4700 mAh, 33.84 Wh

### NOTES

- Samsung Electronics Co., Ltd reserves the right to change the specifications without notice.
- Weight and dimensions are approximate.
- Battery Play time and Battery charge time vary with use conditions.
- In an extremely cold or hot environment, charging stops for safety. To resolve these issues, disconnect the AC power cord and connect it again in an operating temperature between 5 °C and 35 °C (41 °F and 95 °F).

## LIMITED WARRANTY TO ORIGINAL CONSUMER PURCHASER WITH PROOF OF PURCHASE AND/OR PROOF OF DELIVERY

This SAMSUNG brand product, as supplied and distributed by SAMSUNG and delivered new, in the original carton to the original consumer purchaser, is warranted by SAMSUNG against manufacturing defects in materials and workmanship for a limited warranty period of:

### **One (1) Year Parts and Labor\*** **(\*90 Days Parts and Labor for Commercial Use)**

This limited warranty begins on the date of delivery to the original consumer purchaser, and is valid only on products purchased and used in the United States. To receive warranty service, the purchaser must contact SAMSUNG for problem determination and service procedures. Warranty service can only be performed by a SAMSUNG authorized service center. The original dated bill of sale and/or proof of delivery must be presented upon request to SAMSUNG or SAMSUNG'S authorized service center. Transportation of the product to and from the service center is the responsibility of the purchaser.

SAMSUNG will repair or replace this product, at our option and at no charge as stipulated herein, with new or reconditioned parts or products if found to be defective during the limited warranty period specified above.

All replaced parts and products become the property of SAMSUNG and must be returned to SAMSUNG. Replacement parts and products assume the remaining original warranty, or ninety (90) days, whichever is longer. SAMSUNG's obligations with respect to software products distributed by SAMSUNG under the SAMSUNG brand name are set forth in the applicable end user license agreement. Non-SAMSUNG hardware and software products, if provided, are on an "AS IS" basis.

Non-SAMSUNG manufacturers, suppliers, publishers, and service providers may provide their own warranties. This limited warranty covers manufacturing defects in materials and workmanship encountered in normal, and except to the extent otherwise expressly provided for in this statement, noncommercial use of this product, and shall not apply to the following, including, but not limited to: damage which occurs in shipment; delivery and installation; applications and uses for which this product was not intended; altered product or serial numbers; cosmetic damage or exterior finish; accidents, abuse, neglect, fire, water, lightning or other acts of nature; use of products, equipment, systems, utilities, services, parts, supplies, accessories, applications, installations, repairs, external wiring or connectors not supplied and authorized by SAMSUNG, or which damage this product or result in service problems; incorrect electrical line voltage, fluctuations and surges; customer adjustments and failure to follow operating instructions, cleaning, maintenance and environmental instructions that are covered and prescribed in the instruction book; product removal or reinstallation; reception problems and distortion related to noise, echo, interference or other signal transmission and delivery problems. SAMSUNG does not warrant uninterrupted or error-free operation of the product.

THERE ARE NO EXPRESS WARRANTIES OTHER THAN THOSE LISTED AND DESCRIBED ABOVE, AND NO WARRANTIES WHETHER EXPRESS OR IMPLIED, INCLUDING, BUT NOT LIMITED TO, ANY IMPLIED WARRANTIES OF MERCHANTABILITY OR FITNESS FOR A PARTICULAR PURPOSE, SHALL APPLY AFTER THE EXPRESS WARRANTY PERIODS STATED ABOVE, AND NO OTHER EXPRESS WARRANTY OR GUARANTEE GIVEN BY ANY PERSON, FIRM OR CORPORATION WITH RESPECT TO THIS PRODUCT SHALL BE BINDING ON SAMSUNG. SAMSUNG SHALL NOT BE LIABLE FOR LOSS OF REVENUE OR PROFITS, FAILURE TO REALIZE SAVINGS OR OTHER BENEFITS, OR ANY OTHER SPECIAL, INCIDENTAL OR CONSEQUENTIAL DAMAGES CAUSED BY THE USE, MISUSE OR INABILITY TO USE THIS PRODUCT, REGARDLESS OF THE LEGAL THEORY ON WHICH THE CLAIM IS BASED, AND EVEN IF SAMSUNG HAS BEEN ADVISED OF THE POSSIBILITY OF SUCH DAMAGES. NOR SHALL RECOVERY OF ANY KIND AGAINST SAMSUNG BE GREATER IN AMOUNT THAN THE PURCHASE PRICE OF THE PRODUCT SOLD BY SAMSUNG AND CAUSING THE ALLEGED DAMAGE. WITHOUT LIMITING THE FOREGOING, PURCHASER ASSUMES ALL RISK AND LIABILITY FOR LOSS, DAMAGE OR INJURY TO PURCHASER AND PURCHASER'S PROPERTY AND TO OTHERS AND THEIR PROPERTY ARISING OUT OF THE USE, MISUSE OR INABILITY TO USE THIS PRODUCT SOLD BY SAMSUNG NOT CAUSED DIRECTLY BY THE NEGLIGENCE OF SAMSUNG. THIS LIMITED WARRANTY SHALL NOT EXTEND TO ANYONE OTHER THAN THE ORIGINAL PURCHASER OF THIS PRODUCT, IS NONTRANSFERABLE AND STATES YOUR EXCLUSIVE REMEDY.

Some states do not allow limitations on how long an implied warranty lasts, or the exclusion or limitation of incidental or consequential damages, so the above limitations or exclusions may not apply to you. This warranty gives you specific legal rights, and you may also have other rights which vary from state to state.

To obtain warranty service, please contact SAMSUNG customer care center.

The benefits of this Limited Warranty extend only to the original purchaser of Samsung products from an authorized Samsung reseller. THIS LIMITED WARRANTY SHALL NOT APPLY TO ANY SAMSUNG PRODUCTS PURCHASED FROM UNAUTHORIZED RESELLERS OR RETAILERS, EXCEPT IN STATES WHERE SUCH RESTRICTION MAY BE PROHIBITED. For a list of Samsung authorized retailers, please go to:

[http://www.samsung.com/us/peaceofmind/authorized\\_resellers.html](http://www.samsung.com/us/peaceofmind/authorized_resellers.html).

## QUESTIONS OR COMMENTS?

Samsung Service Center 📞	Web Site
1-800-SAMSUNG (726-7864)	<a href="http://www.samsung.com/us/support">www.samsung.com/us/support</a>