



6 SERIES ALL INDUCTION COOKTOPS

Viking Virtuoso 6 Series – MVIC

COMMERCIAL-TYPE COOKING POWER

- MagneQuick™ Induction Elements convert electricity into a magnetic field, which reacts with iron in your cookware and instantly transforms the pan into the heat source
- The heat is then quickly and efficiently transferred into your food, eliminating heat transfer loss into your kitchen and making induction cooking more than 90% efficient – the most energy efficient form of surface cooking
- Induction elements heat more quickly than gas or electric burners, saving time as well as energy
- Induction elements respond instantly to temperature adjustments, so when you lower the heat, you will see the results immediately, just as you see with a gas burner
- Since the heat is generated by the cookware itself, the cooktop surface remains cooler and less prone to cooked on spillovers - much easier to clean than traditional electric cooktops
- Simmer setting is perfect for gentle melting or keeping cooked food warm
- Cooktop can be installed flush or standard mount
- Power Management System provides a boost of superior power on for faster boiling

▪ 30"W. MODEL

- 3,700 watt - 9" element
- 3,000 watt - 8" element
- 3,000 watt - 8" element
- 2,200 watt - 7" element

▪ 36"W. MODEL

- 5,500 watt - 11" element
- 3,000 watt - 8" element
- 3,000 watt - 8" element
- 2,200 watt - 7" element
- 2,200 watt - 7" element



MVIC630



MVIC636

SAFE, EASY OPERATION

- Easy to use touch controls
- Element lights indicate hot surfaces and active elements
- Sensor turns off element if cookware is not detected; pause function
- Two timer functions - cooking element and stand alone

MODEL NUMBERS

- MVIC6304BBG – 30"W. Induction Cooktop; four burners
- MVIC6365BBG – 36"W. Induction Cooktop; five burners

COLOR FINISHES

- Available in Black Glass

WARRANTY

- 2-year full - complete product
- 90-day full - cosmetic parts such as glass, painted items and decorative items
- 5-year limited - induction element components

INDUCTION COOKTOPS

DESCRIPTION	MVIC6304B	MVIC6365B
Overall Width	30" (76.2 cm)	36" (91.4 cm)
Overall Height from Bottom	To top of cooking surface: 2-1/4" (5.7 cm) To bottom edge of frame :.2" (5.1 cm)	
Overall Depth from Rear	21" (53.3 cm)	
Cutout Width	28-1/2" (72.4 cm) minimum to 29" (73.7 cm) maximum	34-1/2" (87.6 cm) minimum to 35" (88.9 cm) maximum
Cutout Depth	19-1/2" (49.5 cm) minimum to 20" (50.8 cm) maximum	
Electrical Requirements	240 VAC; 60Hz; factory-installed 4 ft. (121.9 cm) fl exible steel conduit 3-wire conduit with a No. 10 ground wire; located on the right rear corner of unit	
Maximum Amp Usage	240V—32.2 amps (7.7 kw)	240V—48.3 amps (11.6 kw)
Surface Element Rating	(2) 1850W / 3000W boost (1) 2300W / 3700W boost (1) 1400W / 2200W boost	(2) 1850W / 3000W boost (2) 1400W / 2200W boost (1) 3000W / 5500W boost
Approximate Shipping Weight	52 lb. (23.6 kg)	56 lb. (24.4 kg)

Please do not prepare installation from brochure data only. See installation instructions for important clearance/installation information.

30"W. COOKTOP

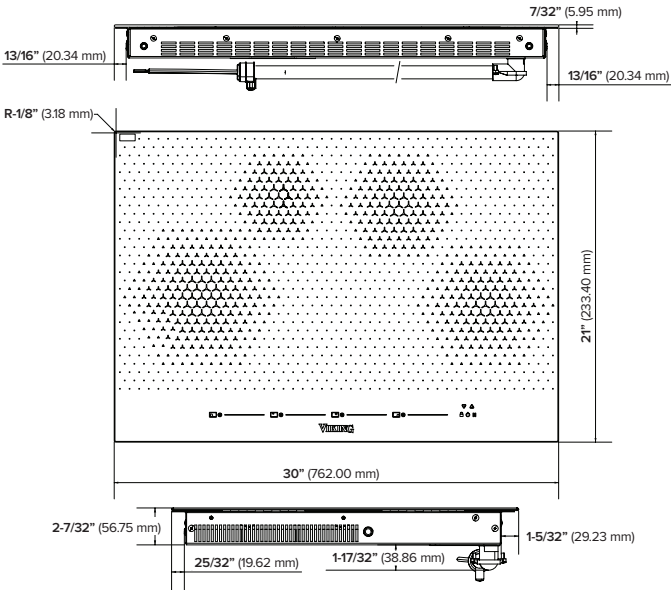

36"W. COOKTOP

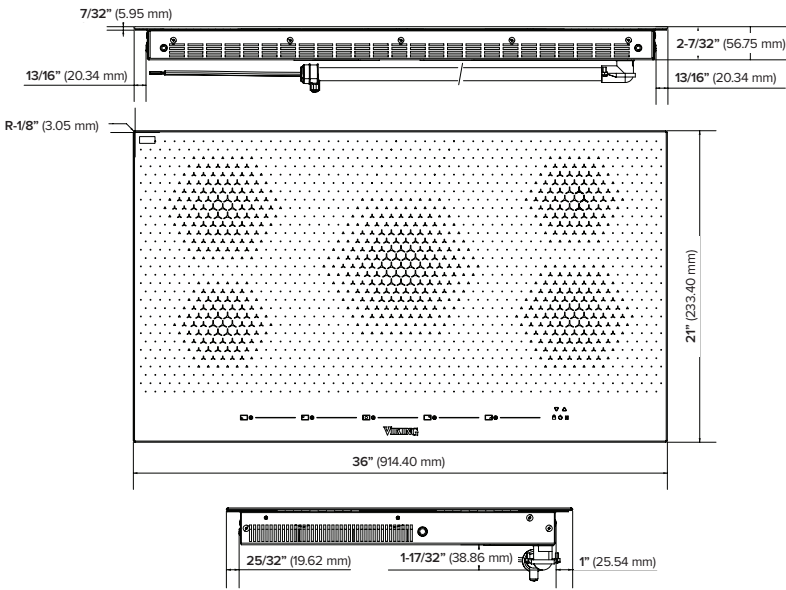

STANDARD INSTALLATION

	30"W. Model	36"W. Model
A	28-1/2" (72.4 cm) min. to 29" (73.7 cm) max.	34-1/2" (87.6 cm) min. to 35" (88.9 cm) max.
B	19-1/2" (49.5 cm) minimum to 20" (50.8 cm) maximum	

FLUSH MOUNT INSTALLATION

	30"W. Model	36"W. Model
A	28-1/8" (73.9 cm)	35-1/8" (89.2 cm)
B	20-1/8" (51.1 cm)	
C	30-1/8" (76.5 cm)	36-1/8" (91.4 cm)
D	21-1/8" (53.7 cm)	

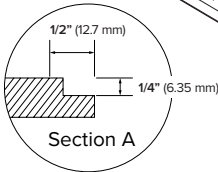
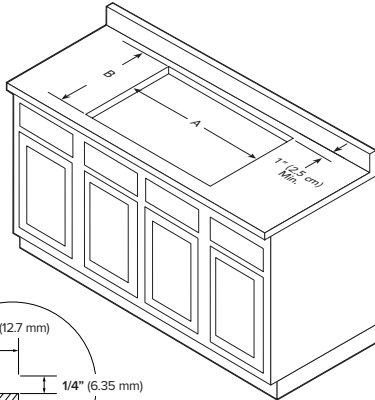
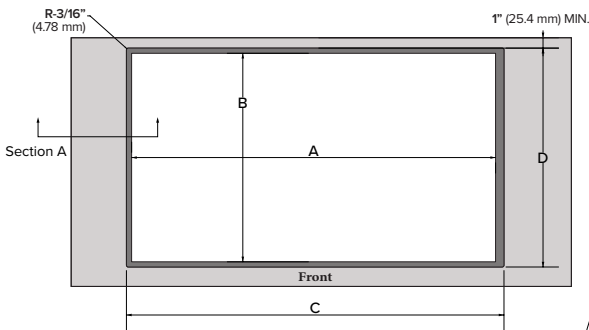

Note: Based on 24" deep cabinet with 3/4" backsplash.



VIKING RANGE, LLC 111 FRONT STREET GREENWOOD, MISSISSIPPI 38930 USA

For detailed product information, model numbers, or to request a quote call 1-888-845-4641 or visit vikingrange.com
© 2023 Viking Range, LLC All rights reserved. Specifications subject to change without notice.

