

MPNP415

15" NUGGET ICE MACHINE



BrightShield protects against viruses, bacteria, mold and mildew.



MARVEL PROFESSIONAL COLLECTION

MAIN FEATURES

- BrightShield™ antimicrobial lighting creates a more hygienic environment for ice
- Produces 3/4" L x 1/2" H cylindrical ice
- Produces up to 90 pounds of nugget ice per day
- Stores up to 30 pounds of nugget ice
- Ice scoop included with dedicated holder
- Factory-installed drain pump included
- Digital controls allow you to select preferred ice density
- Door ajar and cleaning alerts
- Adjustable LED theater-style lighting in arctic white or sapphire blue (non-BrightShield models)
- Elegant midnight black interior
- Professional styling: Robust full-length handle and stainless steel accents
- Reversible soft-close door allows for right or left swing
- Panel ready model requires 3/4" or 5/8" custom panel and handle (not supplied by Marvel)

WARRANTY

- 3-year parts and labor warranty with product registration and 5-year sealed system parts warranty (see complete warranty for details)

FINISH OPTIONS



BRIGHTSHIELD™ MODELS	MODEL NUMBER
Solid Stainless Steel	MPNP415-SS81A
Solid Panel Ready	MPNP415-IS81A

ACCESSORY	PART NUMBER
In-Line Water Filter Head 3/8" NPT	S41016345-ACCY
In-Line Water Filter (Standard)	S41016343-ACCY
Nugget Ice Cleaner Kit*	S41016346-ACCY
Nugget Ice Cleaner (Single 8 oz. Bottle)	S41015681
Internal Water Filter (QTY 1)	S41016405-ACCY

*Includes (1) bottle of nugget ice cleaner, funnel and tubing





DIMENSIONAL DRAWINGS

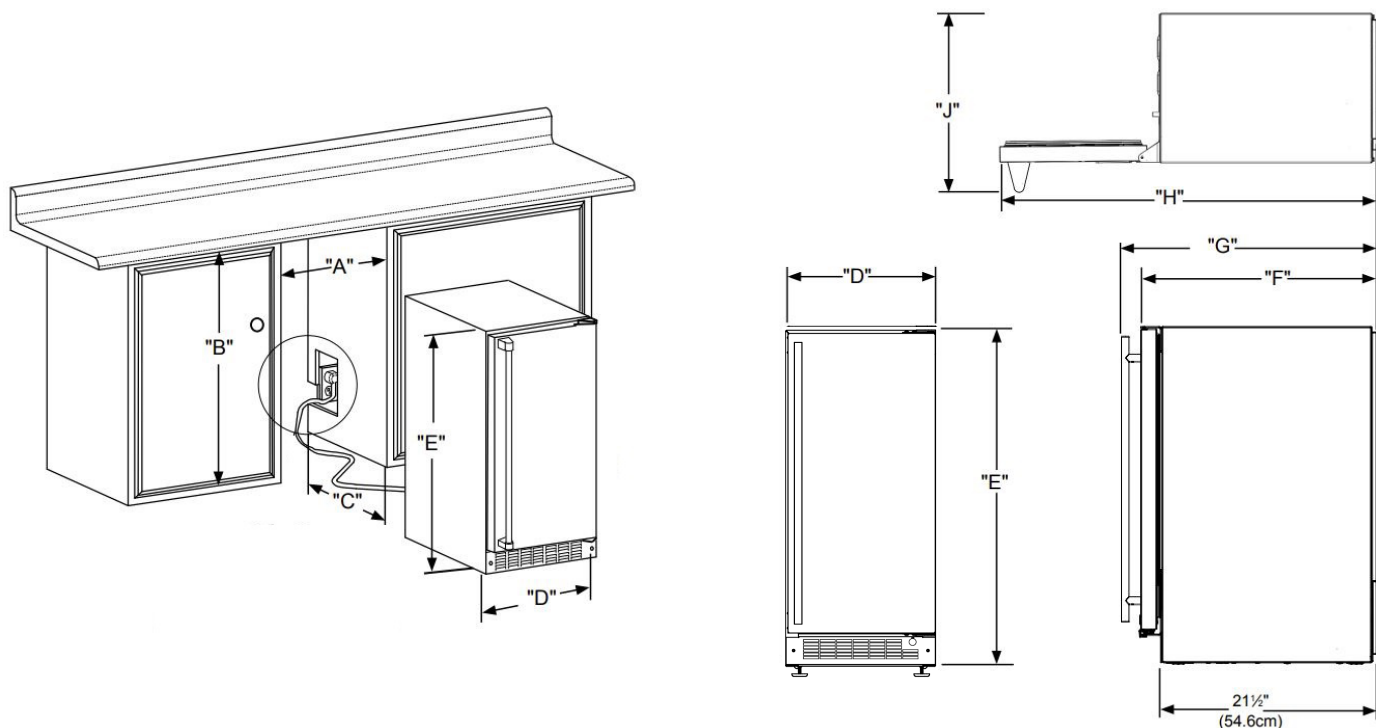

ROUGH IN DIMENSIONS*

"A"	"B"	"C"
15-1/4"	34-1/4" to 35-1/4"	24"
(38.7 cm)	(87 cm to 88.9 cm)	(61 cm)

CABINET DIMENSIONS*

"D"	"E"	"F"	"G"	"H"	"J"
14-15/16"	34-1/8" to 35-11/16"	22-15/16"*	24-13/16"*	38-5/8"*	17-1/2"*
(37.9 cm)	(86.7 cm to 89.2 cm)	(58.3 cm)	(63 cm)	(98 cm)	(44.5 cm)

*Stainless steel model dimensions only. For panel-ready models, see the owner's guide online at marvelrefrigeration.com.

PRODUCT SPECIFICATIONS

Capacity	30 lbs
Cord Length	6 ft.
Electrical Requirements	115V / 60 Hz / 15A
ENERGY STAR	No
Panel Height	30-7/16" (77.3 cm)
Panel Thickness	5/8" (1.6 cm) or 3/4" (1.9 cm)
Panel Type	2-3/4" (7 cm) Solid Panel
Panel Width	14-3/4" (37.5 cm)
Refrigerant Type	R600a

Sabbath Mode	Yes
Shipping Dimensions	19" W x 31" D x 37" H
Shipping Weight	125 lbs

For comprehensive installation instructions, including panel overlay details, please visit marvelrefrigeration.com to access the owner's guide. All specifications are subject to change without notice.