



# Simple User Guide

HW-Q990H / HW-Q900H

You can access the User guide on Samsung's on-line customer support center by scanning the QR code on the left. To see the manual on your PC or mobile device, download the manual in document format from Samsung's website. (<http://www.samsung.com/support>)

- Figures and illustrations in this Simple User Guide are provided for reference only and may differ from actual product appearance.
- An administration fee may be charged if either:
  - An engineer is called out to your home at your request and there is no defect in the product.
  - You bring the unit to a repair center and there is no defect in the product.
- You will be advised of the amount of the administration fee before any work is done or a home visit is made.
- If you have a problem with this product, we strongly recommend you read the appropriate section of this manual, visit the Support page for your product at [www.samsung.com](http://www.samsung.com), or call Samsung Product Support (1-800-726-7864) to find an answer before you contact a service center for a repair.

**QUESTIONS OR COMMENTS?**  
 Samsung Service Center ☎ 1-800-SAMSUNG (726-7864)  
 Website [www.samsung.com/us/support](http://www.samsung.com/us/support)

© 2026 Samsung Electronics Co., Ltd. All rights reserved.

## 01 Checking the Components

- Soundbar
- Subwoofer
- Surround Speaker x 2 (HW-Q990H only)
- Remote Control / Battery
- Power Cable x 4 (HW-Q990H only)
- Power Cable x 2 (HW-Q900H only)
- HDMI Cable
- Wall-mounting Guide
- Holder Screw x 2
- Screw (M4 x L10) x 2
- Wall-mounting Bracket x 2
- Rubber-Foot x 4

**Note**

- To purchase additional components or optional cables, contact a Samsung Service Center or Samsung Customer Care.
- Some components may differ by model and region, and may not be provided. (e.g., HDMI cable, batteries, etc.)

## 02 Product Overview

Top side

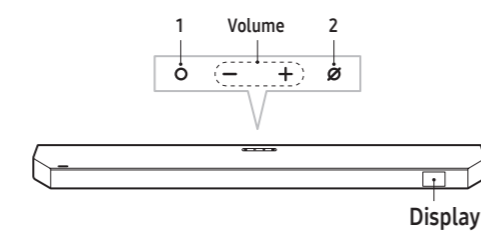

- (Multi) Button**  
 In Standby mode, you can turn on the soundbar by pressing the **○ (Multi)** button. You can switch the input source by pressing the **○ (Multi)** button.
- ⊗ (Microphone) button**  
 Press the button to turn the microphone on or off. When the microphone is off, the LED indicator will turn red. Press and hold the **⊗ (Microphone)** button on the top of the soundbar for 3 seconds or longer to switch to **BT PAIRING** mode.

Bottom side

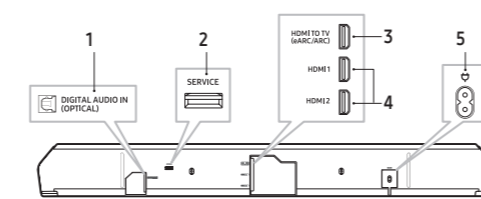

- DIGITAL AUDIO IN (OPTICAL)**  
 Connect to a digital (optical) output terminal of TV or external devices.
- SERVICE**  
 Use this port to update firmware through USB.
- HDMI TO TV (eARC/ARC)**  
 Use this HDMI port to connect to a TV.
- HDMI 1 / HDMI 2**  
 This port is used for connecting an HDMI cable to transmit digital video and audio simultaneously. Connect to an HDMI output for external devices.
- ♥ (POWER)**  
 Connect the power cable to this power port.

## 03 Connecting the Soundbar to Other Units

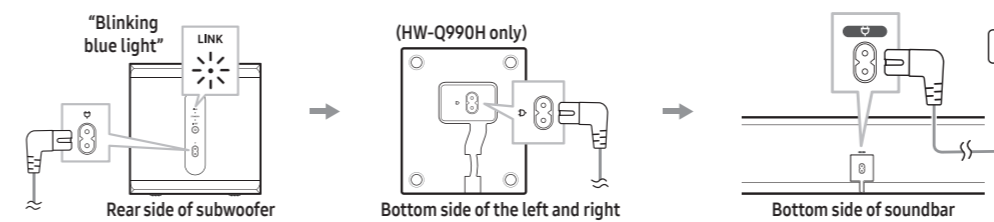

- When the soundbar is properly connected to the subwoofer and surround speakers, the LINK LED indicator will stop blinking and turn solid blue.
- Note**  
 Adjust the surround speakers to position them effectively for optimal surround sound. For more information, please refer to the User Guide on the Samsung Electronics website.

## 04 Connecting to the Samsung Sound App

### 1 Installing App

- You can control the soundbar and adjust settings using the Samsung Sound app.
- Download the Samsung Sound app from your mobile device's app store (App Store, Play Store) or scan the provided QR code.



### 2 Registering a Device

- On your mobile device, run the Samsung Sound app.
- Follow the instructions displayed to register the product to your mobile device.
- If a pop-up window does not appear, go to the app's home screen and tap the **(+)** button to register the product.

**Note**

You can also register your soundbar to the Samsung Sound app by scanning the QR code on the soundbar.

### 3 Controlling the soundbar with Samsung Sound

- Open the Samsung Sound app on your mobile device, and then select the soundbar you have registered.
- The settings menu will appear for the soundbar, and you can adjust the settings such as **Volume**, **Sound Mode**, and **Equalizer**.
- If another user wants to control the soundbar,
  - Make sure the mobile device is connected to the same Wi-Fi network as the soundbar.
  - Open the Samsung Sound app and follow the on-screen instructions to complete the setup. Once the setup is finished, the soundbar can be controlled through the app.

## 06 Using the Q-Symphony Feature

If you connect the soundbar to a Samsung TV that supports Q-Symphony, sound will play from both the soundbar and TV at the same time. You can enjoy a richer, more immersive sound with the TV's surround sound.

When the soundbar is connected to your TV, "Q-Symphony" will appear on your TV. (Home (🏠) → Settings (⚙️) → All Settings (⚙️) → Sound → Sound Output)

## 07 Connecting to Bluetooth

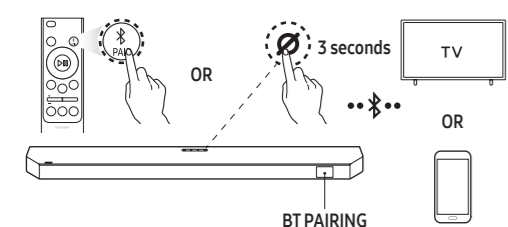

- Press the **⌘** connection button on the remote control or press and hold the **⊗ (Microphone)** button for 3 seconds or longer.
- Search for Bluetooth devices on your TV or mobile device.

**Note**  
 • If prompted for a PIN code when connecting to a Bluetooth device, enter **<0000>**.

## 08 Using the Soundbar Remote Control

- The layout, buttons, and functions of the remote control may vary depending on the model.

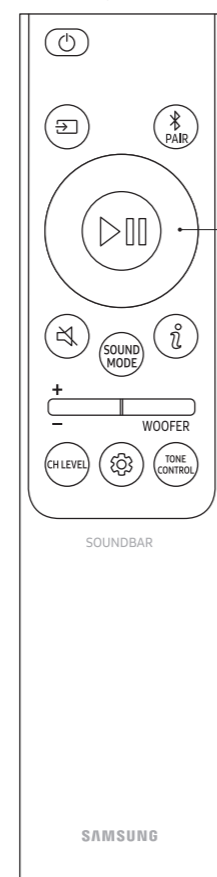

- (POWER)**
- (Input source):** You can select a device connected to the soundbar.
- (Bluetooth):** Press it to enter the Bluetooth pairing mode on the soundbar.
- 1** Directional button (Up/Down/Left/Right)
- (Play/Pause)**
- (Mute):** Press this button to mute the sound. Press it again to unmute.
- (SOUND MODE)** Press it to select a sound mode.
- (Info):** Press this button to see codec information or the current status. In the Bluetooth mode, connected devices will be displayed.
- (Volume)**
  - To mute the sound, press the button.
- WOOFER** You can adjust the subwoofer (bass) levels by pushing the button up or down.
- (CH LEVEL)** You can adjust the volume levels of each speaker. Press the Up or Down buttons to configure the channel you want to adjust.
  - The channel level specifications may vary depending on the model.
- (Sound Settings):** You can adjust and customize the audio settings. Press the Up or Down buttons to configure the sound settings you want to change.
  - Sound settings may vary by model.
- (TONE CONTROL)** You can adjust the treble and bass volume levels. Press the Up or Down buttons to configure the sound settings you want to change.

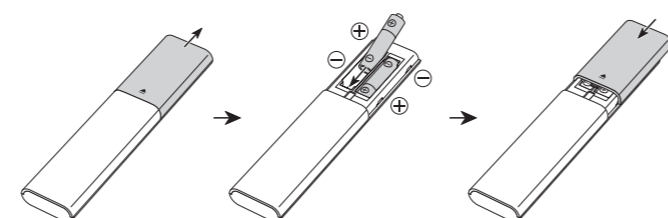

## 09 Installing the Soundbar

### Installing the soundbar on top of the TV stand

- Make sure the soundbar is placed on a flat and solid surface.
- If the soundbar is too close to the TV, voice recognition may be affected, and audio issues could occur.
- As shown in the image, align the center of the TV with the center of the soundbar, then carefully place the soundbar into the TV stand. Make sure the microphone is not blocked when placing the soundbar near the stand to ensure proper voice recognition.
- The actual product may vary in appearance from the image above, depending on the model.

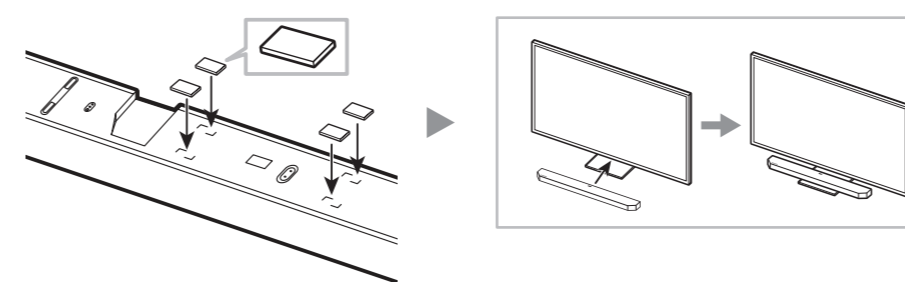

### Installing the soundbar on a wall

- Mount the soundbar only on a vertical wall.
- Avoid installing the soundbar system in areas with high temperatures or humidity.
- Install the system on a sturdy wall capable of supporting the soundbar's weight. If the wall can't support the soundbar's weight, reinforce it before installation. If reinforcement is not possible, choose a different wall that can support the soundbar.
- Use screws or anchor brackets suitable for the wall where the soundbar is being installed. (Gypsum board/steel/wood, etc.) If possible, install the screws directly into the wall.
- Turn off the power and unplug the soundbar before mounting it on the wall. Failure to do so may result in electric shock.
- Connect all cables from external devices before mounting the soundbar on the wall.

## 05 Connecting to TV

### 5-1 Connecting to a TV with Cables

Connecting an HDMI Cable

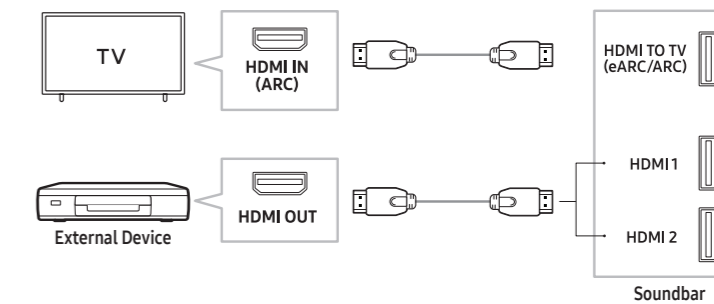

Connecting to an Optical Cable

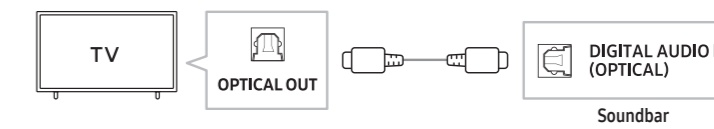

**Note**

- If there is no sound from the soundbar, press the **○ (Multi)** button on the top of the soundbar or press the **(Source)** button on the remote control to switch to the appropriate connected mode.
- Using HDMI cables certified by HDMI.org is recommended.
- When using an optical cable, make sure to remove the cover from the optical cable before use.

### 5-2 Connecting to a TV through Wi-Fi

On the TV Sound menu, change the input source to soundbar.

- Samsung TVs released in 2017 or later: Home (🏠) → Settings (⚙️) → All Settings (⚙️) → Sound → Sound Output → Soundbar (Wi-Fi)

**Note**

- Wi-Fi connection is available only on Samsung TV.
- Connect the soundbar and TV to the same Wi-Fi network.
- Check your TV's manual, as the menu may vary depending on the year of manufacture.

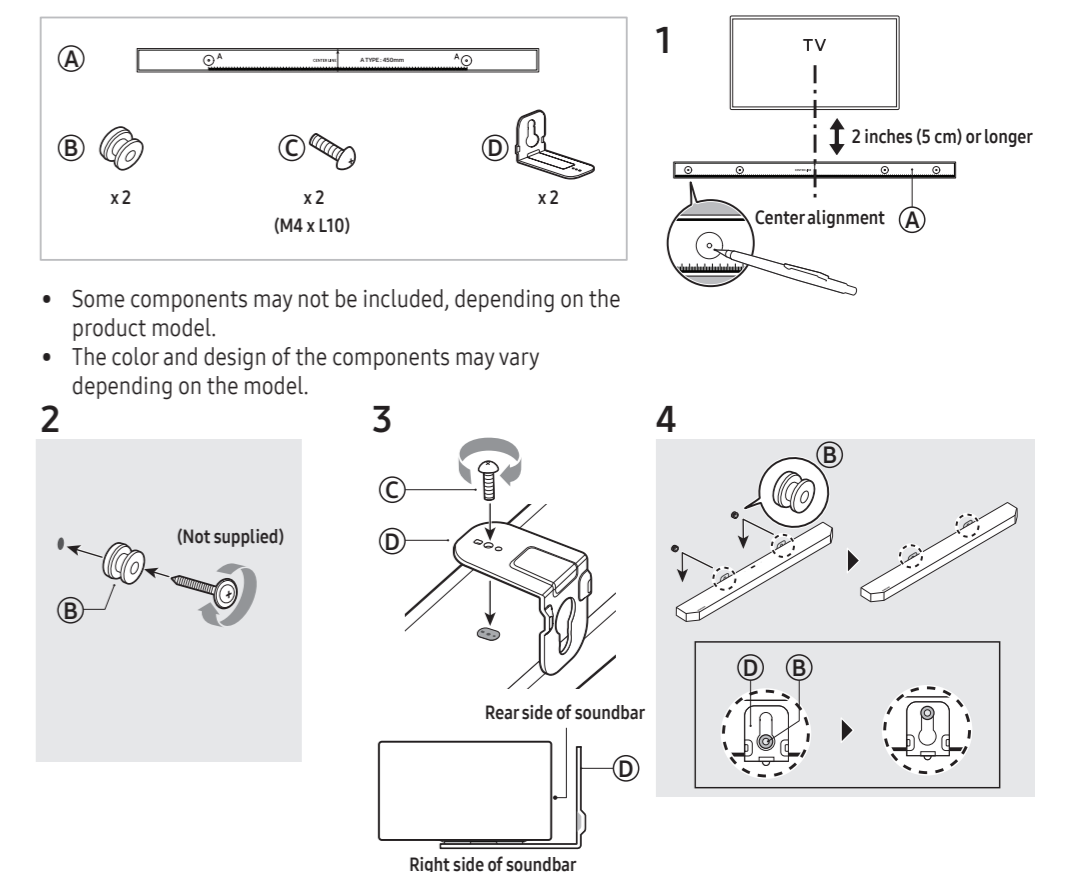

**Note: When mounting surround speakers on a wall (only applicable to certain models)**

- The wall used to mount the surround speakers must be able to support at least 17.6 lbs (8 kg).
- Hole size: fits 1/4 - 20 UNC screw
  - Standard screw: 0.25 inches (6.35 mm) ø, 0.05 inches (1.27 mm) pitch / Length: 0.7 inches (18 mm)
  - Quantity: 1 for the left speaker, 1 for the right speaker
- Samsung Electronics doesn't sell wall mounts.

## 10 Troubleshooting

Refer to the instructions below if this product does not function properly. If the problem you are experiencing is not listed below or if the instructions below do not help, turn off the product, disconnect the power cord, and contact Samsung Electronics at 1-800-SAMSUNG (1-800-726-7864).

### When the power does not turn on

- Check if the power cord is securely connected to the soundbar.

### If the subwoofer and surround speakers don't connect to the soundbar automatically

- Press and hold **ID SET** on the rear of the subwoofer and surround speakers for 5 seconds or longer.

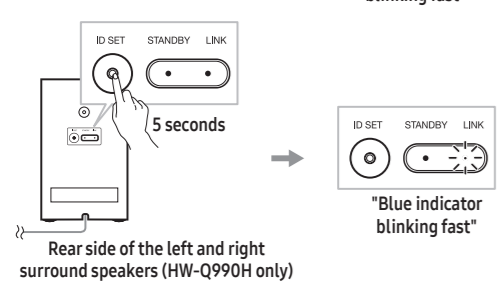
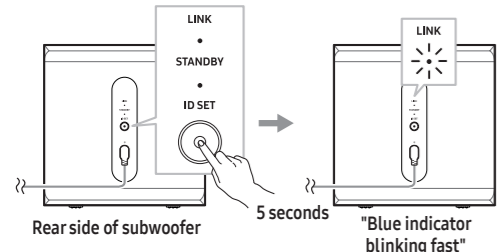

- Press and hold the **UP** button on the soundbar remote control for 5 seconds.

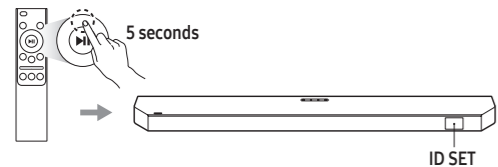

- Make sure the LINK LED indicator turns blue (indicating a successful connection).
  - When the soundbar is properly connected to the subwoofer and surround speakers, the LINK LED indicator will stop blinking and turn solid blue.

### When some functions are not working properly

- Unplug the power cord, then plug it back in.
- Unplug the power cord from the external device and try again.
- If there is no signal input, the soundbar will automatically turn off after a certain period. Turn on the power.

### If the remote control is not working properly

- Bring the remote control closer to the soundbar and point it directly at the soundbar to select inputs.
- Replace the batteries with fresh ones.

### When the soundbar indicator light stays red

- The microphone is turned off. When the microphone is turned on, the indicator will turn off.

### If there is no sound

- The soundbar volume may be low, or the soundbar may be set to mute. Adjust the volume levels.
- When using external devices (STB, Bluetooth device, mobile device, etc.) connected to the soundbar, adjust the volume on each device.
- The sound output may be set to the TV. Select the soundbar as the sound output for the TV. (Samsung TV: Home ( ) → Settings ( ) → All Settings ( ) → Sound → Sound Output → Select Soundbar)
- Unplug the power cord from the soundbar and plug it in again.

### If there is no sound from the subwoofer or surround speakers

- Check if the LED indicator on the rear of the subwoofer or surround speaker is blue. If the indicator is red or blinking blue, reconnect the soundbar to the subwoofer and surround speakers.
- If there are devices near the Soundbar that may cause wireless interference, the sound may be interrupted. Keep them at least 3.3 ft (1 m) away. Examples: Wireless router or smart outlet with an automatic standby power cut-off feature.

### When the TV can't connect to the HDMI TO TV (eARC/ARC)

- Make sure the HDMI cable is securely connected to the ARC or eARC port.
- The soundbar connection may not work due to other devices (such as set-top boxes, game consoles, etc.) connected to the TV. Connect only the soundbar to the TV, without any other devices.
- HDMI-CEC may not be enabled on the TV. Enable CEC in the TV menu. (Samsung TV: Home ( ) → Settings ( ) → All Settings ( ) → General & Privacy → External Device Manager → Anynet+ (HDMI-CEC) ON)
  - The menu path may vary depending on the model.

### When a Bluetooth connection can't be established

- When connecting a new device to the soundbar, switch to BT PAIRING to connect. Press the **BT** button on the soundbar remote control or press and hold the **Ⓜ (Microphone)** button for 3 seconds or longer.
- Remove the speaker from the Bluetooth speaker list in the device, then reconnect. (Samsung TV: Home ( ) → Settings ( ) → All Settings ( ) → Sound → Sound Output → Bluetooth Speaker List)

### When the audio stutters due to a weak Bluetooth connection

- Audio may stutter if the soundbar is placed near an electronic device or appliance that causes radio interference. (e.g., microwave oven, wireless router, etc.)
- The sound may cut out if the connected device is too far from the soundbar. Please move the device closer to the soundbar.
- If your body is in contact with the Bluetooth transmitter or the soundbar is placed on metal furniture, the audio may stutter. Check the installation environment and conditions.

### When a Wi-Fi connection can't be established

- Check if your wireless router is on. Turn off the router, then turn it back on and try reconnecting.
- If the wireless router signal is weak, it may not be possible to connect to Wi-Fi. Move the wireless router closer to the soundbar or place it in an unobstructed location.

### When the TV is powered on, but the soundbar does not turn on with it

- If you turn off the soundbar first while watching TV, the Auto Power Link feature on the soundbar will be turned off. Power off the TV first.

### The TV does not show the UHD input signal.

- You may need to adjust the settings on your TV or source device. Refer to your TV or device manual for more details.
- Check if your Ultra High Speed HDMI cable is certified by HDMI.org.

## 11 Specifications and Information

<b>Model name:</b>	HW-Q990H	<b>Operating temperature range</b>	+ 50 °F to +104 °F (+10 °C to +40 °C)	<b>Operating humidity range</b>	10 % – 80 %, non-condensing
<b>Weight</b>	16.1 lbs (7.3 kg)	<b>Dimensions (width x height x depth)</b>	48.5 x 2.8 x 5.4 inches (1232.0 x 70.8 x 138.0 mm)	<b>Storing temperature range</b>	-4 °F to +113 °F (-20 °C to +45 °C)
<b>Subwoofer name:</b>	PS-WQ990H	<b>Weight</b>	18.3 lbs (8.3 kg)	<b>Storing humidity level range</b>	5 % – 95 %, non-condensing
<b>Weight</b>	18.3 lbs (8.3 kg)	<b>Dimensions (width x height x depth)</b>	9.8 x 9.9 x 9.8 inches (249.0 x 251.8 x 249.0 mm)	<b>Precaution : When you activate or deactivate the Wi-Fi or Bluetooth connectivity, the soundbar will automatically restart.</b>	<ul style="list-style-type: none"> <li>Press and hold the <b>CH LEVEL</b> button on the remote control for 30 seconds or longer to activate or deactivate the Wi-Fi.</li> <li>Press and hold the <b>TONE CONTROL</b> button on the soundbar remote control for 30 seconds or longer to activate or deactivate the Bluetooth.</li> </ul>
<b>Surround speaker name:</b>	PS-RQ990H (LEFT/RIGHT)	<b>Weight</b>	7.5 lbs (3.4 kg)	<b>Supported formats for playback</b>	Dolby 5.1ch / Dolby Digital Plus / Dolby TRUE HD / Dolby ATMOS / DTS 5.1ch / DTS HD / DTS-HD Master Audio / DTS:X / LPCM 8Ch
<b>Weight</b>	7.5 lbs (3.4 kg)	<b>Dimensions (width x height x depth)</b>	5.1 x 7.9 x 5.5 inches (129.5 x 201.3 x 140.4 mm)	<b>FCC NOTE (for U.S.A.):</b>	<p><b>FCC Supplier's Declaration of Conformity Responsible Party - U.S. Contact Information:</b> Samsung Electronics America, Inc. 700 Sylvan Avenue, Englewood Cliffs, NJ 07632 Phone: 1-800-SAMSUNG (726-7864)</p>
<b>Model name:</b>	HW-Q900H	<b>Weight</b>	16.1 lbs (7.3 kg)	<b>Dimensions (width x height x depth)</b>	48.5 x 2.8 x 5.4 inches (1232.0 x 70.8 x 138.0 mm)
<b>Subwoofer name:</b>	PS-WQ900H	<b>Weight</b>	18.3 lbs (8.3 kg)	<b>Dimensions (width x height x depth)</b>	9.8 x 9.9 x 9.8 inches (249.0 x 251.8 x 249.0 mm)

## Safety Information

- The following also applies to the Subwoofer and Surround Speaker SET.

### SAFETY WARNINGS

TO REDUCE THE RISK OF ELECTRIC SHOCK, DO NOT REMOVE THE COVER (OR BACK). NO USER-SERVICEABLE PARTS ARE INSIDE. REFER SERVICING TO QUALIFIED SERVICE PERSONNEL. Refer to the table below for an explanation of symbols which may be on your Samsung product.

	<b>CAUTION</b> <b>RISK OF ELECTRIC SHOCK.</b> <b>DO NOT OPEN.</b>	
	This symbol indicates that high voltage is present inside. It is dangerous to make any kind of contact with any internal part of this product.	
	This symbol indicates that this product has included important literature concerning operation and maintenance.	
	Class II product : This symbol indicates that a safety connection to electrical earth (ground) is not required. If this symbol is not present on a product with a power cord, the product MUST have a reliable connection to protective earth (ground).	
	AC voltage : Rated voltage marked with this symbol is AC voltage.	
	DC voltage : Rated voltage marked with this symbol is DC voltage.	
	Caution. Consult Instructions for use : This symbol instructs the user to consult the user manual for further safety related information.	

### Important Safety Instructions

Read these operating instructions carefully before using the unit. Follow all the safety instructions listed below. Keep these operating instructions handy for future reference.

- Read these instructions.
- Keep these Instructions.
- Heed all warnings.
- Follow all instructions.
- Do not use this apparatus near water.
- Clean only with dry cloth.
- Do not block any ventilation openings. Install in accordance with the manufacturer's instructions.
- Do not install near any heat sources such as radiators, heat registers, stoves, or other apparatus (including amplifiers) that produce heat.
- Do not hinder in any way the safety purpose of the polarized or grounding-type plug. A polarized plug has two blades with one wider than the other. A grounding type plug has two blades and a third grounding prong. The wide blade or the third prong are provided for your safety. If the provided plug does not fit into your outlet, consult an electrician for replacement of the obsolete outlet.
- Protect the power cord from being walked on or pinched particularly at plugs, convenience receptacles, and the point where they exit from the apparatus.
- Only use attachments/accessories specified by the manufacturer.
- Use only with the cart, stand, tripod, bracket, or table specified by the manufacturer, or sold with the apparatus. When a cart is used, use caution when moving the cart/apparatus combination to avoid injury from tip-over.



- Unplug this apparatus during lightning storms or when unused for long periods of time.

- Refer all servicing to qualified service personnel. Servicing is required when the apparatus has been damaged in any way, such as power-supply cord or plug is damaged, liquid has been spilled or objects have fallen into the apparatus, the apparatus has been exposed to rain or moisture, does not operate normally, or has been dropped.

## Precautions

- Ensure that the AC power supply in your house complies with the power requirements listed on the identification sticker located on the bottom of your product. Install your product horizontally, on a suitable base (furniture), with enough space around it for ventilation (3–4 inches). Make sure the ventilation slots are not covered. Do not place the unit on amplifiers or other equipment which may become hot. This unit is designed for continuous use. To fully turn off the unit, disconnect the AC plug from the wall outlet. Unplug the unit if you intend to leave it unused for a long period of time.
- During thunderstorms, disconnect the AC plug from the wall outlet. Voltage peaks due to lightning could damage the unit.
- Do not expose the unit to direct sunlight or other heat sources. This could lead to overheating and cause the unit to malfunction.
- Protect the product from moisture (i.e. vases), and excess heat (e.g. a fireplace) or equipment creating strong magnetic or electric fields. Unplug the power cable from the AC wall socket if the unit malfunctions. Your product is not intended for industrial use. It is for personal use only. Condensation may occur if your product has been stored in cold temperatures. If transporting the unit during the winter, wait approximately 2 hours until the unit has reached room temperature before using.
- The battery used with this product contains chemicals that are harmful to the environment. Do not dispose of the battery in the general household trash. Do not expose the battery to excess heat, direct sunlight, or fire. Do not short circuit, disassemble, or overheat the battery. CAUTION : Danger of explosion if the battery is replaced incorrectly. Replace only with the same or equivalent type.

### FCC Compliance Statement :

This device complies with Part 15 of the FCC Rules. Operation is subject to the following two conditions:

- This device may not cause harmful interference, and
- this device must accept any interference received, including interference that may cause undesired operation.

### FCC Caution :

- Any changes or modifications not expressly approved by the party responsible for compliance could void the user's authority to operate this equipment.
- This product satisfies FCC regulations when shielded cables and connectors are used to connect the unit to other equipment. To prevent electromagnetic interference with electric appliances, such as radios and televisions, use shielded cables and connectors for connections.

### Class B FCC Statement

This equipment has been tested and found to comply with the limits for a Class B digital device, pursuant to Part 15 of the FCC Rules. These limits are designed to provide reasonable protection against harmful interference in a residential installation. This equipment generates, uses and can radiate radio frequency energy and, if not installed and used in accordance with the instructions, may cause harmful interference to radio communications. However, there is no guarantee that interference will not occur in a particular installation. If this equipment does cause harmful interference to radio or television reception, which can be determined by turning the equipment off and on, the user is encouraged to try to correct the interference by one of the following measures:

- Reorienting or relocating the receiving antenna.
- Increasing the separation between the equipment and receiver.
- Connecting the equipment to an outlet that is on a different circuit than the radio or TV.

- Consulting the dealer or an experienced radio/TV technician for help.

### FCC Radiation Exposure Statement :

This equipment complies with FCC radiation exposure limits set forth for an uncontrolled environment. This equipment should be installed and operated so there is at least 8 inches (20 cm) between the radiator and your body. This device and its antenna(s) must not be co-located or operated in conjunction with any other antenna or transmitter.

### CALIFORNIA USA ONLY (Applicable for networking models only.)

This Perchlorate warning applies only to primary CR(Manganese Dioxide) Lithium coin cells in the product sold or distributed ONLY in California USA "Perchlorate Material - special handling may apply. See [www.dtsc.ca.gov/hazardouswaste/perchlorate](http://www.dtsc.ca.gov/hazardouswaste/perchlorate)."

**⚠ WARNING: Cancer and Reproductive Harm - www.P65Warnings.ca.gov.**

### Samsung products and recycling

- Dispose unwanted electronics through an approved recycler. To find the nearest recycling location, go to our website: [www.samsung.com/recycling](http://www.samsung.com/recycling) Or call, 1-800-SAMSUNG
- WARNING!** Never dispose of batteries in a fire because they may explode. Do not disassemble, crush, puncture, heat, burn or reuse batteries. For more information, visit [call2recycle.org](http://call2recycle.org) or call 1-800-822-8837. Alternatively, visit: [www.samsung.com/recycling](http://www.samsung.com/recycling) or call 1-800-SAMSUNG.

## LIMITED WARRANTY TO ORIGINAL CONSUMER PURCHASER WITH PROOF OF PURCHASE AND/OR PROOF OF DELIVERY

This SAMSUNG brand product, as supplied and distributed by SAMSUNG and delivered new, in the original carton to the original consumer purchaser, is warranted by SAMSUNG against manufacturing defects in materials and workmanship for a limited warranty period of:

**One (1) Year Parts and Labor\*  
(\*90 Days Parts and Labor for Commercial Use)**

This limited warranty begins on the date of delivery to the original consumer purchaser, and is valid only on products purchased and used in the United States. To receive warranty service, the purchaser must contact SAMSUNG for problem determination and service procedures. Warranty service can only be performed by a SAMSUNG authorized service center. The original dated bill of sale and/or proof of delivery must be presented upon request to SAMSUNG or SAMSUNG's authorized service center. Transportation of the product to and from the service center is the responsibility of the purchaser. SAMSUNG will repair or replace this product, at our option and at no charge as stipulated herein, with new or reconditioned parts or products if found to be defective during the limited warranty period specified above.

All replaced parts and products become the property of SAMSUNG and must be returned to SAMSUNG. Replacement parts and products assume the remaining original warranty, or ninety (90) days, whichever is longer. SAMSUNG's obligations with respect to software products distributed by SAMSUNG under the SAMSUNG brand name are set forth in the applicable end user license agreement. Non-SAMSUNG hardware and software products, if provided, are on an "AS IS" basis. Non-SAMSUNG manufacturers, suppliers, publishers, and service providers may provide their own warranties. This limited warranty covers manufacturing defects in materials and workmanship encountered in normal, and except to the extent otherwise expressly provided for in this statement, noncommercial use of this product, and shall not apply to the following, including, but not limited to: damage which occurs in shipment; delivery and installation; applications and uses for which this product was not intended; altered product or serial numbers; cosmetic damage or exterior finish; accidents, abuse, neglect, fire, water, lightning or other acts of nature; use of products, equipment, systems, utilities, services, parts, supplies, accessories, applications, installations, repairs, external wiring or connectors not supplied and authorized by SAMSUNG, or which damage this product or result in service problems; incorrect electrical line voltage, fluctuations and surges; customer adjustments and failure to follow operating instructions, cleaning, maintenance and environmental instructions that are covered and prescribed in the instruction book; product removal or reinstallation; reception problems and distortion related to noise, echo, interference or other signal transmission and delivery problems. SAMSUNG does not warrant uninterrupted or error-free operation of the product.

THERE ARE NO EXPRESS WARRANTIES OTHER THAN THOSE LISTED AND DESCRIBED ABOVE, AND NO WARRANTIES WHETHER EXPRESS OR IMPLIED, INCLUDING, BUT NOT LIMITED TO, ANY IMPLIED WARRANTIES OF MERCHANTABILITY OR FITNESS FOR A PARTICULAR PURPOSE, SHALL APPLY AFTER THE EXPRESS WARRANTY PERIODS STATED ABOVE, AND NO OTHER EXPRESS WARRANTY OR GUARANTEE GIVEN BY ANY PERSON, FIRM OR CORPORATION WITH RESPECT TO THIS PRODUCT SHALL BE BINDING ON SAMSUNG. SAMSUNG SHALL NOT BE LIABLE FOR LOSS OF REVENUE OR PROFITS, FAILURE TO REALIZE SAVINGS OR OTHER BENEFITS, OR ANY OTHER SPECIAL, INCIDENTAL OR CONSEQUENTIAL DAMAGES CAUSED BY THE USE, MISUSE OR INABILITY TO USE THIS PRODUCT, REGARDLESS OF THE LEGAL THEORY ON WHICH THE CLAIM IS BASED, AND EVEN IF SAMSUNG HAS BEEN ADVISED OF THE POSSIBILITY OF SUCH DAMAGES. NOR SHALL RECOVERY OF ANY KIND AGAINST SAMSUNG BE GREATER IN AMOUNT THAN THE PURCHASE PRICE OF THE PRODUCT SOLD BY SAMSUNG AND CAUSING THE ALLEGED DAMAGE. WITHOUT LIMITING THE FOREGOING, PURCHASER ASSUMES ALL RISK AND LIABILITY FOR LOSS, DAMAGE OR INJURY TO PURCHASER AND PURCHASER'S PROPERTY AND TO OTHERS AND THEIR PROPERTY ARISING OUT OF THE USE, MISUSE OR INABILITY TO USE THIS PRODUCT SOLD BY SAMSUNG NOT CAUSED DIRECTLY BY THE NEGLIGENCE OF SAMSUNG. THIS LIMITED WARRANTY SHALL NOT EXTEND TO ANYONE OTHER THAN THE ORIGINAL PURCHASER OF THIS PRODUCT, IS NONTRANSFERABLE AND STATES YOUR EXCLUSIVE REMEDY.

Some states do not allow limitations on how long an implied warranty lasts, or the exclusion or limitation of incidental or consequential damages, so the above limitations or exclusions may not apply to you. This warranty gives you specific legal rights, and you may also have other rights which vary from state to state. To obtain warranty service, please contact SAMSUNG customer care center. The benefits of this Limited Warranty extend only to the original purchaser of Samsung products from an authorized Samsung reseller. THIS LIMITED WARRANTY SHALL NOT APPLY TO SAMSUNG PRODUCTS PURCHASED FROM UNAUTHORIZED RESELLERS OR RETAILERS, EXCEPT IN STATES WHERE SUCH RESTRICTION MAY BE PROHIBITED. For a list of Samsung authorized retailers, please go to: [http://www.samsung.com/us/peaceofmind/authorized\\_resellers.html](http://www.samsung.com/us/peaceofmind/authorized_resellers.html).