

PureLine
60cm Speed Oven

H 6200 BM



PureLine 60cm Speed Oven H 6200 BM



H 6200 BM

Features:

- DirectSelect controls offer turn dial operation with a 7-segment liquid crystal display
- 9 operating modes
- Rapid Preheat
- PerfectClean interior
- 1,000 watt microwave
- Popcorn button
- Minute Plus button - time and power individually programmable
- Timer
- The simple yet sleek Silhouette handle seems to float enhancing its modern design lines

PureLine 60cm Speed Oven H 6200 BM



Comfort Handle:
Optional with ContourLine
(DS 6708 Item #09828380)

ComfortSwivel Handle:
Standard with ContourLine
Optional for PureLine
(DS 6718 Item # 09828390)

Silhouette Handle:
Standard with Pureline
Optional for Contourline
(DS 6808 Item # 09828400)

Silhouette Handle (Chrome):
Standard with BrilliantWhite
(DS 6808 Item # 09828410)

Silhouette Handle:
Standard with Truffle Brown
(DS 6808 Item # 09870690)

PureLine 60cm Speed Oven H 6200 BM



SPECIFICATIONS	
H 6200 BM – Item 22620054USA	
Overall Unit Width - Excluding Fascia Dimension	22 ¹ / ₁₆ " (560mm)
Overall Height - Excluding Fascia Dimension	17 ¹ / ₂ " (445mm)
Overall Unit Depth - Excluding Fascia Dimension	21 ⁹ / ₁₆ " (549mm)
Oven Door Clearance	34 ¹³ / ₁₆ " (885mm)
Overall Oven Interior Capacity	1.31 cu.ft - 37.0 liters
Overall Fascia Dimensions	23 ⁷ / ₁₆ " (595mm) W x 17 ¹⁵ / ₁₆ " (455.5mm) H x 7 ⁷ / ₈ " (22mm) D
Oven Interior Dimensions	18 ¹ / ₈ " (460mm) W x 8" (202mm) H x 15 ⁵ / ₈ " (390mm) D
Built-In	
Cabinet Width	22 ¹ / ₁₆ " – 22 ³ / ₈ " (561mm – 568mm)
Minimum Cabinet Depth	min. 21 ⁷ / ₈ " (550mm)
Minimum Cabinet Opening Height	17 ³ / ₄ " – 17 ¹³ / ₁₆ " (448 – 452mm)
Minimum Base Support	125 lbs
Additional Cut-outs Required	No
Electrical	
Electrical Requirements	240/208V AC, 60Hz, 20A circuit with Nema 14-30 outlet
Power Cord	Molded NEMA 14-30 configured plug
Cut out for power cord	Minimum 3" square
Electrical Rating	2.2kW (240V), 1.76kW (208V)
Total Amps	9.16A on 240V, 8.46A on 208V
Shipping	
Shipping Weight	126 lbs
Shipping Dimensions	25 ⁵ / ₈ " W (727mm) x 24 ¹³ / ₁₆ " (630mm) H x 27" (686mm) L
Support	
Call	800.843.7231
20/20	☎2020technologies.com

PureLine 60cm Speed Oven H 6200 BM



PRODUCT VIEWS

Fascia

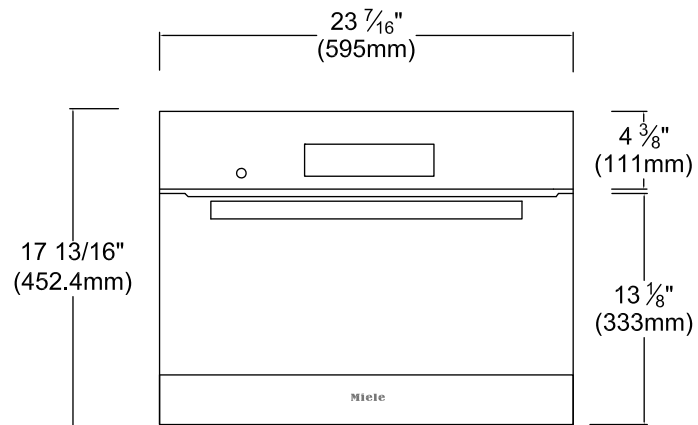

Top View

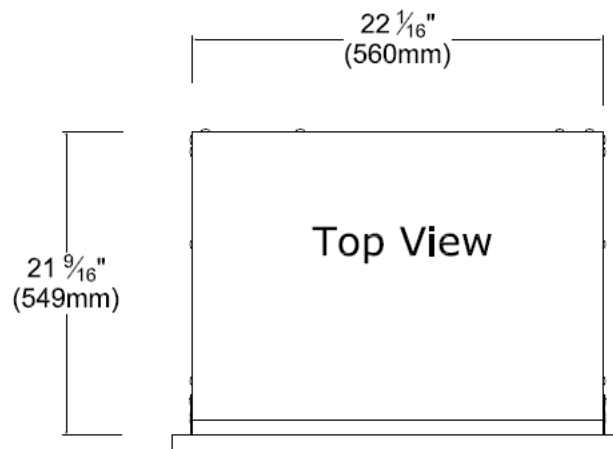

PRODUCT VIEWS

Rear View

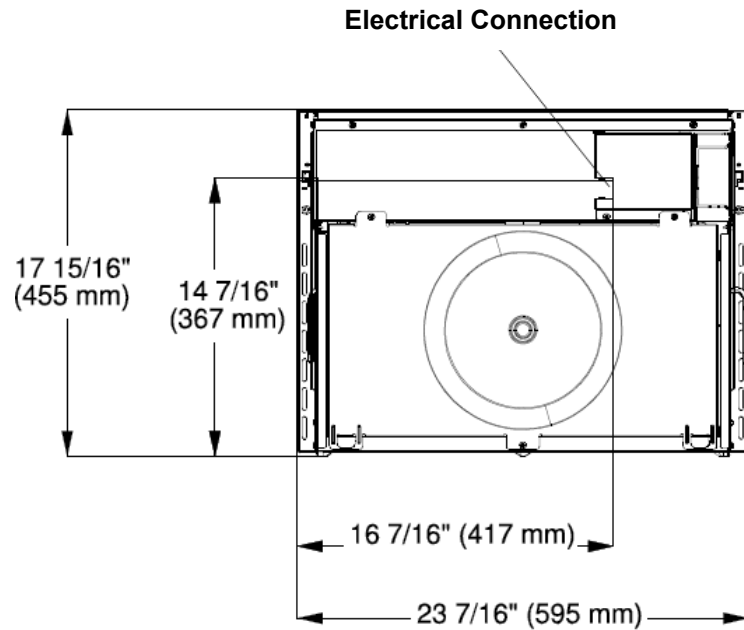

Side View

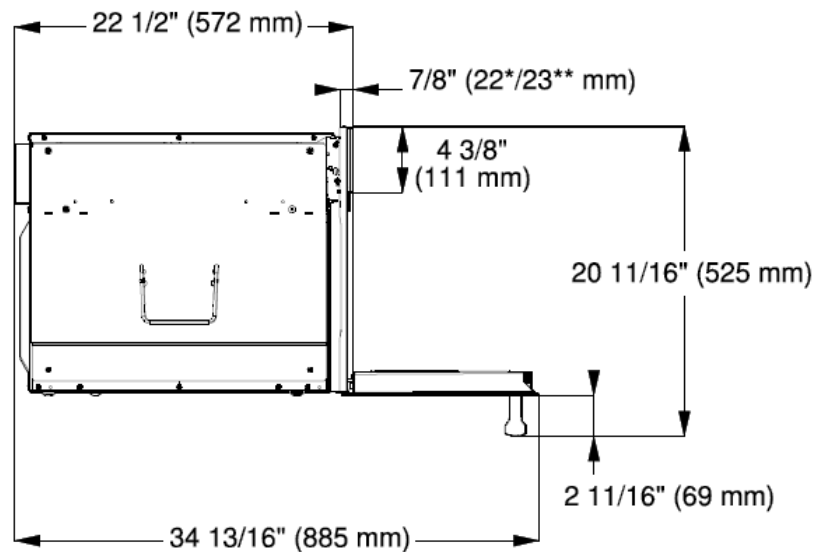

* Oven with glass front
** Oven with metal front

PureLine 60cm Speed Oven H 6200 BM



INSTALLATION SPECIFICATIONS

Install in Tall Cabinet

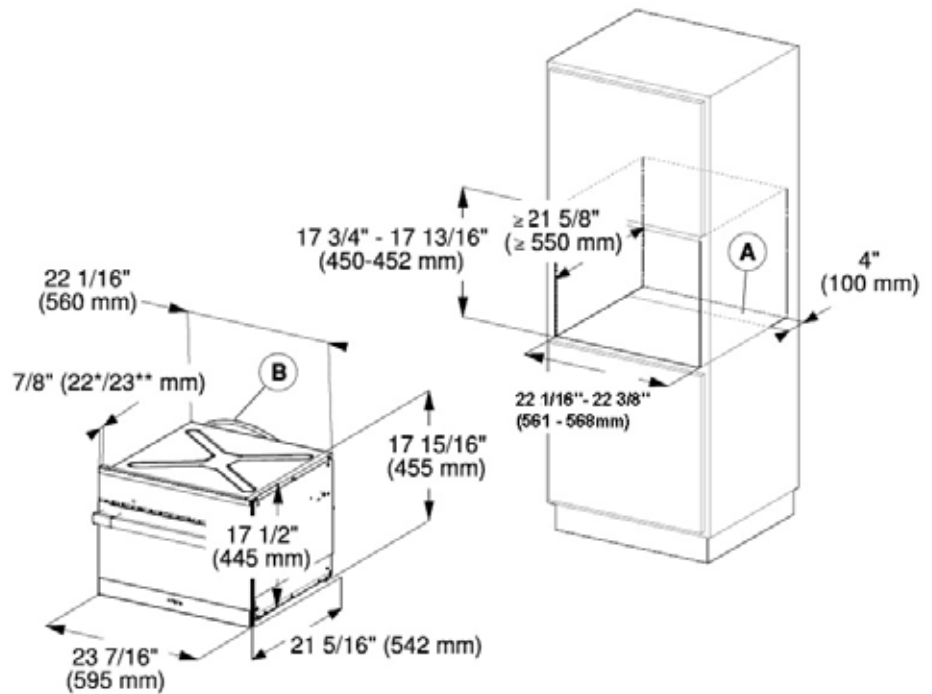

* Oven with glass front
** Oven with metal front

Undercounter Installation

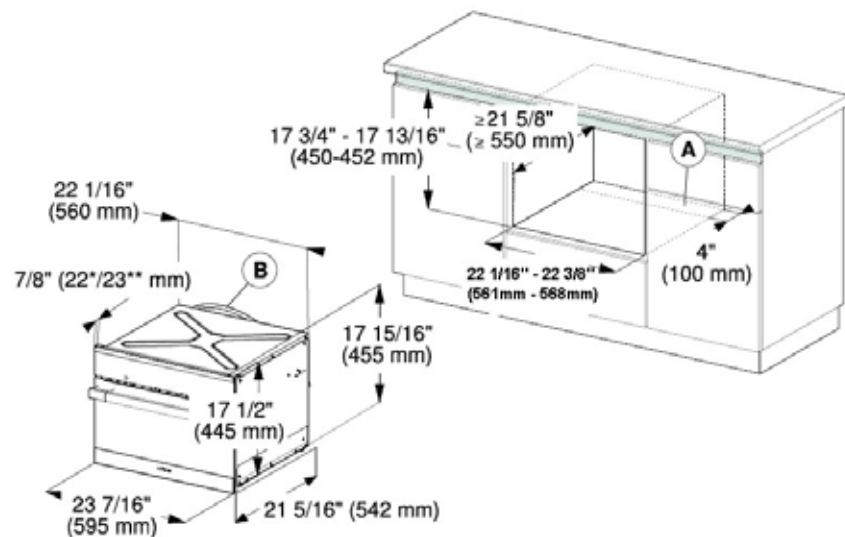

* Oven with glass front
** Oven with metal front

PureLine 60cm Speed Oven H 6200 BM



INSTALLATION SPECIFICATIONS

Over 60cm Installation

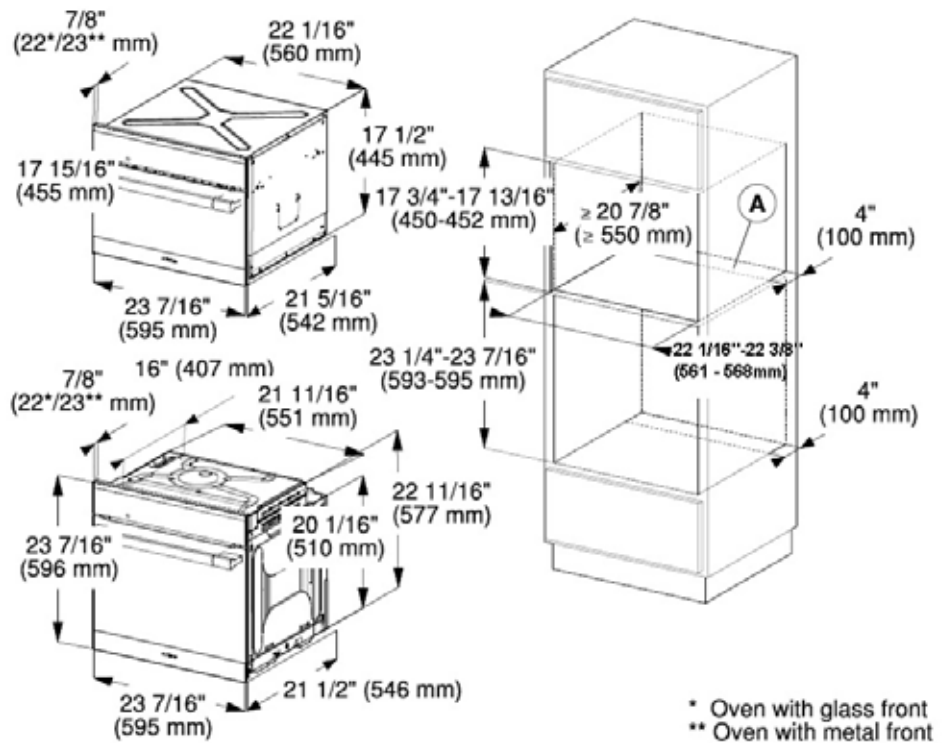

INSTALLATION SPECIFICATIONS

Door Swing

Front dimensions

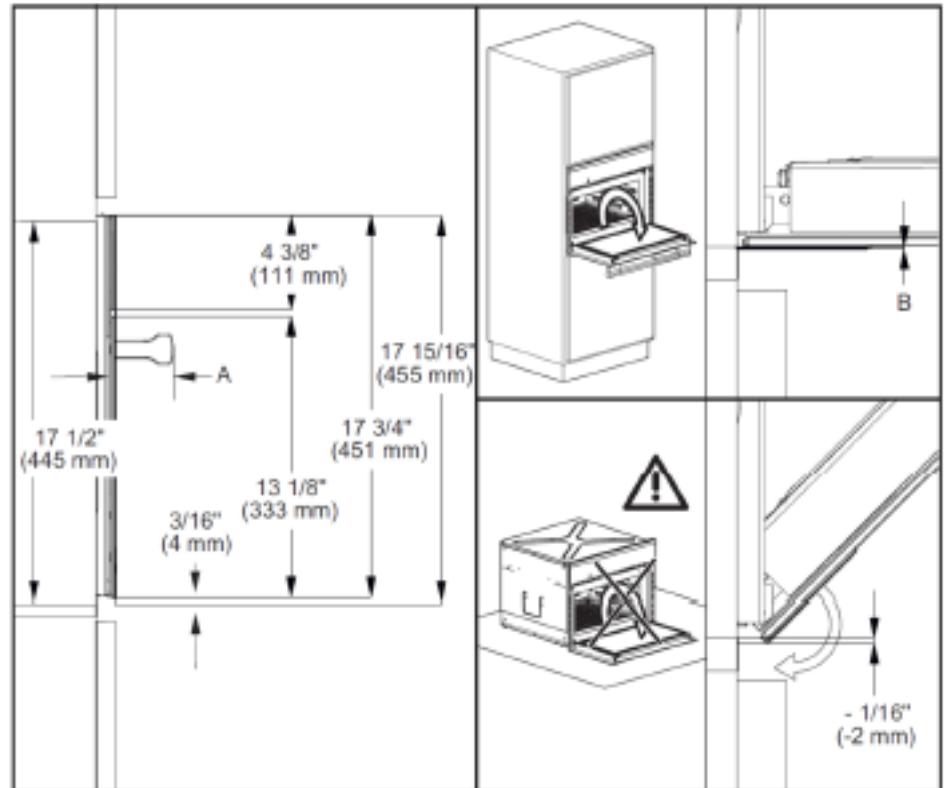

- A** H67xx: 2 3/4" (69 mm)
H68xx: 1 5/8" (42 mm)
- B** Speed Oven with glass front: 1/16" (2.2 mm)
Speed Oven with metal front: 1/16" (1.2 mm)