

EN User Manual | Freezer



## Welcome to our family

Thank you for bringing Frigidaire into your home! We see your purchase as the beginning of a long relationship together.

This manual is your resource for the use and care of your product. Please read it before using your appliance. Keep it handy for quick reference. If something doesn't seem right, the troubleshooting section will help you with common issues.

FAQ, helpful tips and videos, cleaning products, and kitchen and home accessories are available at <http://www.frigidaire.com>.

We are here for you! Visit our website, chat with an agent, or call us if you need help. We may be able to help you avoid a service visit. If you do need service, we can get that started for you.

Let's make it official! Be sure to register your product.

## CONTENTS

1. SAFETY IMPORTANT INFORMATION.....	2
2. INSTALLATION.....	5
3. DOOR REMOVAL AND REVERSAL.....	6
4. FEATURES.....	6
5. CONTROLS AND SETTINGS.....	7
6. CARE AND CLEANING.....	8
7. TROUBLESHOOTING.....	8
8. LIMITED WARRANTY.....	9
9. QUEBEC RIGHT TO REPAIR.....	11

## 1. SAFETY IMPORTANT INFORMATION

### 1.1 Keep a record for quick reference

Model number

.....

Serial number

.....

Purchase date

.....

### 1.2 Serial number location

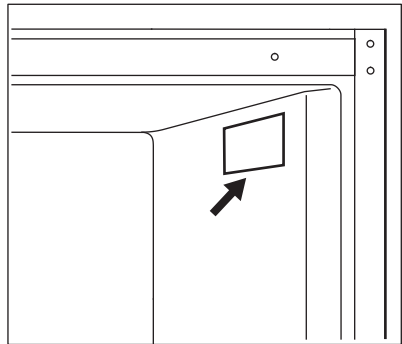

#### **⚠ WARNING!**

You must follow these guidelines to ensure that your refrigerator's safety mechanisms are operating correctly.

### 1.3 Safety definitions



This is the safety alert symbol. It is used to alert of potential personal injury hazards. Obey all safety messages that follow this symbol to avoid possible injury or death.

 **DANGER**

DANGER indicates an imminently hazardous situation which, if not avoided, will result in death or serious injury.

 **WARNING!**

WARNING indicates a potentially hazardous situation which, if not avoided, could result in death or serious injury.

 **CAUTION!**

CAUTION indicates a potentially hazardous situation which, if not avoided, may result in minor or moderate injury.

 **IMPORTANT**

IMPORTANT indicates installation, operation or maintenance information which is important but not hazard-related.

 **DANGER**

DANGER Risk of fire or explosion. Flammable refrigerant used. Do not use mechanical devices to defrost refrigerator. Do not puncture refrigerant tubing. DANGER Risk of fire or explosion. Flammable refrigerant used. To be repaired only by trained service personnel. Use only manufacturer-authorized service parts. Any repair equipment used must be designed for flammable refrigerants. Follow all manufacturer repair instructions. Do not puncture refrigerant tubing.



 **CAUTION!**



CAUTION Risk of fire or explosion. Dispose of refrigerator properly in accordance with the applicable federal or local regulations. Flammable refrigerant used.

CAUTION Risk of fire or explosion due to puncture of refrigerant tubing. Follow handling instructions carefully. Flammable refrigerant used.

 **WARNING!**

CALIFORNIA RESIDENTS ONLY  
WARNING! Cancer and Reproductive Harm <http://www.P65Warnings.ca.gov>

### 1.4 Child safety

This appliance is not intended for use by persons (including children) with reduced physical, sensory or mental capabilities, or lack of experience and knowledge, unless they have been given supervision or instruction concerning use of the appliance by a person responsible for their safety.

Destroy or recycle the carton, plastic bags, and any exterior wrapping material immediately after the refrigerator is unpacked. Children should never use these items to play. Cartons covered with rugs, bedspreads, plastic sheets or stretch wrap may become airtight chambers, and can quickly cause suffocation.

### 1.5 Important safety instructions

Do not store or use gasoline or other flammable vapors and liquids in the vicinity of this or any other appliance.

Do not store explosive substances such as aerosol cans with a flammable propellant in this appliance.

Do not operate the refrigerator in the presence of explosive fumes

Avoid contact with any moving parts of automatic ice maker.

Remove all staples from the carton. Staples can cause severe cuts, and also destroy finishes if they come in contact with other appliances or furniture.



## WARNING!

Do not use electrical appliances inside the food storage compartments of the appliance unless they are of the type recommended by the manufacturer.

### 1.6 Proper disposal of your refrigerator or freezer

#### Risk of child entrapment

Child entrapment and suffocation are not problems of the past. Junked or abandoned refrigerators or freezers are still dangerous – even if they will sit for “just a few days”. If you are getting rid of your old refrigerator or freezer, follow the instructions below to help prevent accidents.

We strongly encourage responsible appliance recycling/disposal methods. Check with your utility company or visit <http://www.energystar.gov/recycle> for more information on recycling your old refrigerator.

#### Before you throw away your old refrigerator/freezer:

- Remove doors.
- Leave shelves in place so children may not easily climb inside.
- Have it removed by a qualified service technician.

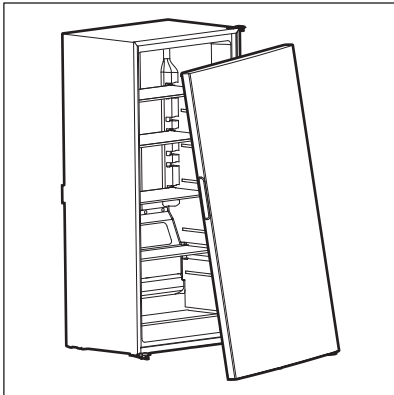

## IMPORTANT

#### CFC/HCFC Disposal

Your old refrigerator may have a cooling system that used CFCs or HCFCs (chlorofluorocarbons or hydrochlorofluorocarbons). CFCs and HCFCs are believed to harm stratospheric ozone if released to the atmosphere. Other refrigerants may also cause harm to the environment if released to the atmosphere. If you are throwing away your old refrigerator, make sure the refrigerant is removed for proper disposal by a qualified technician. If you intentionally release refrigerant, you may be subject to fines and imprisonment under provisions of environmental legislation.

### 1.7 Electrical information



## IMPORTANT

Turning on the appliance controls to OFF will disable the appliance cooling system but does not disconnect the power to the light bulb and other electrical components. To turn off power to the appliance you must unplug the power cord from the electrical outlet.

- The appliance must be plugged into its own dedicated 115 Volt, 60 Hz., 15 Amp, AC only electrical outlet. The power cord of the appliance is equipped with a three-prong grounding plug for your protection against electrical shock hazards. It must be plugged directly into a properly grounded three-prong receptacle. The receptacle must be installed in accordance with local codes and ordinances. Consult a qualified electrician. Do not use an extension cord or adapter plug.



## WARNING!

Avoid fire hazard or electric shock.

- If the power cord is damaged, it should be replaced by an authorized service technician to prevent any risk.
- Never unplug the appliance by pulling on the power cord. Always grip the plug

firmly, and pull straight out from the receptacle to prevent damaging the power cord.

- Unplug the appliance before cleaning and before replacing the light bulb to avoid electrical shock.
- Performance may be affected if the voltage varies by 10% or more. Operating the appliance with insufficient power can damage the compressor. Such damage is not covered under your warranty.
- Do not plug the unit into an electrical outlet controlled by a wall switch or pull cord to prevent the appliance from being turned off accidentally.

- Do not pinch, knot, or bend the power cord in any manner.

### **⚠ WARNING!**

Do not, under any circumstances, cut, remove, or bypass the grounding prong (A). Always use the power cord with a three-prong grounded plug and grounding type wall receptacle.



## 2. INSTALLATION

This User Manual provides general installation and operating instructions for your model. We recommend using a service or kitchen contracting professional to install your appliance. Use the appliance only as instructed in this User Manual. Before starting the appliance, follow these important first steps.

### 2.1 Location

- If possible, place the appliance out of direct sunlight and away from the range, dishwasher, or other heat sources.
- The appliance must be installed on a floor that is level and strong enough to support a fully loaded appliance.

### **⚠ WARNING!**

This appliance is intended for use in residential household and similar interior applications such as:

- Kitchen / kitchenette
- Pantry room
- Basement
- Enclosed garage
- Other interior residential type environments

### **📌 IMPORTANT**

This appliance is garage-ready. It is designed to operate in ambient temperatures between 0°F (-18°C) and 110°F (43°C).

### **⚠ CAUTION!**

This appliance is convertible and can operate as a refrigerator or a freezer. Do not install the appliance where the temperature:

- raises above 110 °F (43 °C).
- drops below 0°F (-18°C).

The compressor will not be able to maintain proper temperatures inside the appliance.

### **⚠ WARNING!**

Allow the following clearances for ease of installation, proper air circulation, plumbing, and electrical connections:

- Sides 3" (75 mm)
- Back 3" (75 mm)

### **📌 NOTE**

The exterior walls of the appliance may become warm as the compressor transfers heat from the inside. The temperatures may be even 30°F higher than the room temperature. In hotter climates it is important to allow enough space for air circulation around the appliance.

### 2.2 Leveling

When positioning the appliance, ensure that it is level, with all bottom corners resting firmly on a solid floor. You can

adjust this using the two leveling feet located at the front bottom of the appliance.

### 3. DOOR REMOVAL AND REVERSAL

#### 3.1 Door Removal/Reversal

Tools required: Phillips™ and flat head screwdrivers.

1. Unplug and empty the appliance.
2. Remove the top hinge cover, the screws and the top hinge.

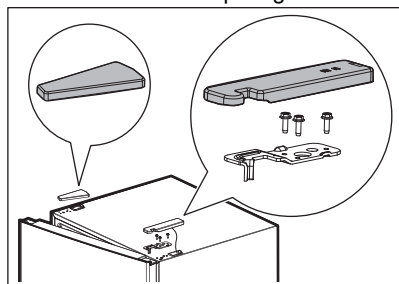

3. Remove the door by lifting it off the bottom hinge. Place it on a padded surface.
4. Remove the lower hinge component and install it on the opposite side.

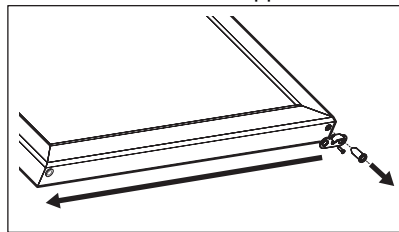

5. Remove the leveling feet and the bottom hinge and install them on the

opposite sides. Do not fully tighten the hinge.

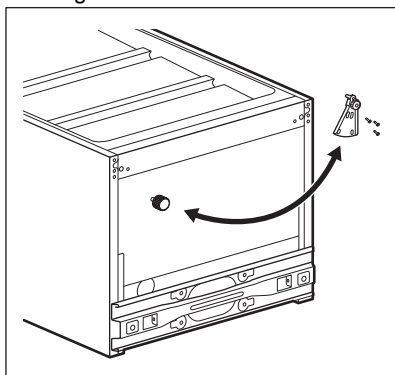

6. Place the freezer door onto the bottom hinge pin and align it vertically and horizontally.
7. Install the upper hinge and the hinge cover.

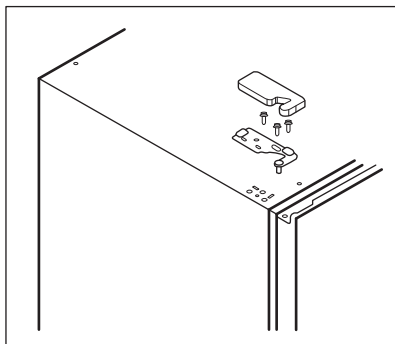

### 4. FEATURES

#### **IMPORTANT**

Features may vary by model.

Accessories are available for your appliance and may be purchased at [Frigidaire.com](http://Frigidaire.com) or by calling toll-free 1-800-374-4432.

## 4.1 Product overview

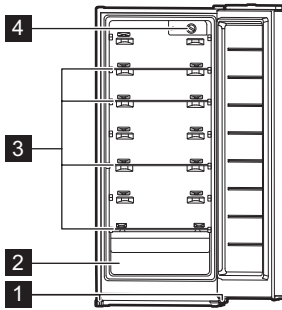

- 1 Leveling Feet
- 2 Drawer
- 3 Glass Shelves
- 4 Freezer Control

## 5. CONTROLS AND SETTINGS

### 5.1 Appliance Control

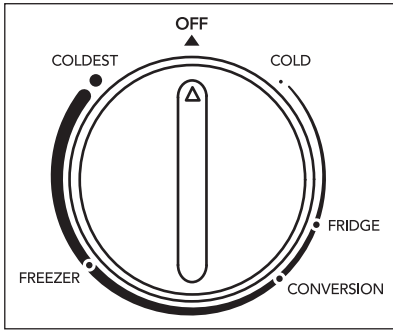

#### **IMPORTANT**

Internal temperatures may vary depending on where the appliance is located, the ambient room temperature, and how often you open the door.

#### **NOTE**

If the appliance is located in a garage or in an area where the temperature is below 50 °F, set the control to the coldest setting to improve freezer performance.

Turn the dial to adjust the temperature. Adjust the temperature gradually in small increments and allow the temperature to stabilize.

The appliance may operate in the freezer mode (FREEZER, COLDEST) or refrigerator mode (COLD, FRIDGE). Use CONVERSION when switching the appliance between refrigerator and freezer operation. Before changing the mode:

- **From freezer to refrigerator:**  
Remove any food you want to keep frozen and store it in another freezer to prevent thawing.
- **From refrigerator to freezer:**  
Remove any food you want to keep fresh and store it in another refrigerator to prevent freezing.

## 6. CARE AND CLEANING

### 6.1 Cleaning

Before cleaning remove food from the appliance and store it well covered.

Clean the appliance interior and accessories regularly with a cloth and lukewarm water.

Do not use abrasive cleaners. After cleaning rinse with fresh water and dry thoroughly with a clean cloth.

#### **CAUTION!**

Unplug the appliance from the power source before cleaning to avoid electrical hazard. Never clean the appliance with a steam cleaner. Allow the appliance to dry before using it.

#### **IMPORTANT**

Do not use organic solvents, such as lemon juice, juice from an orange peel, butyric acid, or cleaners containing acetic acid.

### 6.2 Defrosting

#### **Before defrosting**

To avoid frequent defrosting, use a plastic scraper to remove frost. Scrape with a pulling motion.

#### **IMPORTANT**

Do not use metal instruments to remove the frost.

It is important to defrost and clean the freezer when 1/4 to 1/2" of frost has accumulated.

#### **WARNING!**

Always unplug the appliance prior to defrosting. Never unplug the appliance by pulling on the power cord. Always grip the plug firmly and pull straight out from the receptacle.

#### **IMPORTANT**

Turning the control to OFF turns off the compressor, but does not disconnect power to other electrical components.

#### **Defrosting**

Frost may tend to accumulate faster on the upper part of the freezer due to warm, moist air entering the appliance when the door is open.

Remove food and leave the door open when defrosting the appliance.

## 7. TROUBLESHOOTING

Let us help you troubleshoot your concern! This section will help you with common issues. If you need us, visit our website, chat with an agent, or call us. We may be able to help you avoid a service visit. If you do need service, we can get that started for you! Visit [Frigidaire.com](http://Frigidaire.com) or call toll-free 1-800-374-4432.

### Appliance Operation

Concern	Potential Cause	Common Solution
The appliance does not run.	The appliance may not be plugged in or the plug may be loose.	Ensure the plug is tightly pushed into the outlet.
	The house fuse may be blown, or the circuit breaker may have tripped.	Check/replace the fuse with a 15-amp time-delay fuse. Reset the circuit breaker.
	The socket may be defective.	Call a qualified electrician.
The temperature inside the appliance is too cold.	The temperature is set to the coolest setting.	Turn the control to a warmer setting.

Concern	Potential Cause	Common Solution
The temperature inside the appliance is too warm.	The temperature is set too the warmest setting.	Turn the control to a colder setting and allow several hours for the temperature to stabilize.
	The door is kept open for too long or is opened too frequently.	Warm air enters the appliance every time the door is opened. Open the door less frequently.
	Large amounts of warm or hot food may have been stored recently.	Wait until the appliance reaches the selected temperature after placing the food inside.
	The appliance has recently been disconnected for a period of time.	The appliance requires 24 hours to cool down completely.

## Sound and Noise

Concern	Potential Cause	Common Solution
Vibrating or rattling noise.	The appliance is not level. It rocks on the floor when moved slightly.	Level the unit. See Leveling section in Installation.
	The floor is uneven or weak, causing the appliance to rock when moved slightly.	Ensure the floor can support the appliance. Level it by placing wood or metal shims under part of the appliance.
	The appliance is touching the wall.	Level the appliance or adjust its position. Refer to the Leveling section in Installation.

## Water/Moisture/Frost Inside the Appliance

Concern	Potential Cause	Common Solution
Moisture is forming on the inside walls.	The weather is hot and humid, which increases the rate of frost build-up inside.	This is normal.
	The door may not be sealing properly.	Carefully warm the leaking sections of the door seal with a cool air from a hair dryer, and simultaneously shape the seal by hand to ensure it seats correctly.
	The door is kept open for too long or is opened too frequently.	Open the door less frequently.

## 8. LIMITED WARRANTY

Your appliance is covered by a one year limited warranty. For one year from your original date of delivery, Electrolux will pay all costs for repairing or replacing any parts of this appliance that prove to be defective in materials or workmanship when such appliance is installed, used and maintained in accordance with the provided instructions. If your product cannot be repaired or replaced, you will be

refunded the purchase price less any depreciation, taxes or other costs.

### Exclusions

This warranty does not cover the following:

1. Products with original serial numbers that have been removed, altered or cannot be readily determined.
2. Product that has been transferred from its original owner to another party or

removed outside the USA, Puerto Rico, or Canada.

3. Rust on the interior or exterior of the unit.
4. Products purchased "as-is" are not covered by this warranty.
5. Food loss due to any refrigerator or freezer failures.
6. Products used in a commercial setting.
7. Service calls which do not involve malfunction or defects in materials or workmanship, or for appliances not in ordinary household use or used other than in accordance with the provided instructions.
8. Service calls to correct the installation of your appliance or to instruct you how to use your appliance.
9. Expenses for making the appliance accessible for servicing, such as removal of trim, cupboards, shelves, etc., which are not a part of the appliance when it is shipped from the factory.
10. Service calls to repair or replace appliance light bulbs, air filters, water filters, other consumables, or knobs, handles, or other cosmetic parts.
11. Surcharges including, but not limited to, any after hour, weekend, or holiday service calls, tolls, ferry trip charges, or mileage expense for service calls to remote areas, including the state of Alaska.
12. Damages to the finish of appliance or home incurred during transportation or installation, including but not limited to floors, cabinets, walls, etc.
13. Damages caused by: services performed by unauthorized service companies; use of parts other than genuine Electrolux parts or parts obtained from persons other than authorized service companies; or external causes such as abuse, misuse, inadequate power supply, accidents, fires, or acts of God.

**DISCLAIMER OF IMPLIED WARRANTIES; LIMITATION OF REMEDIES**

CUSTOMER'S SOLE AND EXCLUSIVE REMEDY UNDER THIS LIMITED WARRANTY SHALL BE PRODUCT REPAIR OR REPLACEMENT AS PROVIDED HEREIN. CLAIMS BASED ON IMPLIED WARRANTIES, INCLUDING WARRANTIES OF MERCHANTABILITY

OR FITNESS FOR A PARTICULAR PURPOSE, ARE LIMITED TO ONE YEAR OR THE SHORTEST PERIOD ALLOWED BY LAW, BUT NOT LESS THAN ONE YEAR. ELECTROLUX SHALL NOT BE LIABLE FOR CONSEQUENTIAL OR INCIDENTAL DAMAGES SUCH AS PROPERTY DAMAGE AND INCIDENTAL EXPENSES RESULTING FROM ANY BREACH OF THIS WRITTEN LIMITED WARRANTY OR ANY IMPLIED WARRANTY. SOME STATES AND PROVINCES DO NOT ALLOW THE EXCLUSION OR LIMITATION OF INCIDENTAL OR CONSEQUENTIAL DAMAGES, OR LIMITATIONS ON THE DURATION OF IMPLIED WARRANTIES, SO THESE LIMITATIONS OR EXCLUSIONS MAY NOT APPLY TO YOU. THIS WRITTEN WARRANTY GIVES YOU SPECIFIC LEGAL RIGHTS. YOU MAY ALSO HAVE OTHER RIGHTS THAT VARY FROM STATE TO STATE.

**If You Need Service**

You must provide the appliance serial number and your receipt, delivery slip, or some other appropriate payment record to establish the warranty period should service be required. If service is performed, it is in your best interest to obtain and keep all receipts. Service under this warranty must be obtained by contacting Electrolux at the addresses or phone numbers below.

This warranty only applies in the USA, Puerto Rico and Canada. In the USA and Puerto Rico, your appliance is warranted by Electrolux Consumer Products, Inc. In Canada, your appliance is warranted by Electrolux Canada Corp. Electrolux authorizes no person to change or add to any obligations under this warranty. Obligations for service and parts under this warranty must be performed by Electrolux or an authorized service company. Product features or specifications as described or illustrated are subject to change without notice.

**USA**

**1-800-374-4432**

Electrolux Consumer Products, Inc.

10200 David Taylor Drive

Charlotte, NC 28262

Canada

1-800-265-8352

Electrolux Canada Corp.

5855 Terry Fox Way

Mississauga, Ontario, Canada L5V 3E4

## 9. QUEBEC RIGHT TO REPAIR

Though Frigidaire makes every effort to make replacement parts, repair services and information necessary to maintain or repair our products available to consumers, parts, service and information are not guaranteed, pursuant to section 39 of the Consumer Protection Act, CQLR, c. P-40.1 and sections 79.18 to 79.20 of the Regulation respecting the application of the Consumer Protection Act, CQLR, c. P-40.1, r. 3. If you need replacement parts, you may call us at 1 (800) 265-8352 for service in French or English, or purchase online at **Frigidaire Parts | Shop Frigidaire Replacement Parts & Accessories - Frigidaire Appliance Parts.**

You may book repair services online at <https://www.frigidaire.ca/RIGHT-TO-REPAIR/>. Alternatively, our resource library is available at **Resource Library | Frigidaire** to help you diagnose and resolve issues which may arise during the lifetime of your appliance.

Though most parts are available for purchase, subject to short-term availability constraints, the following appliances and parts are not serviceable.

### Legend

#### Availability of replacement parts, repair services, and information for maintenance or repair.



Partially Available



Not Available



Available

#### Refrigerators



Cabinet, 14cu ft and less no sealed system parts

#### Freezer



9 cu. ft and less no sealed system parts.

#### Beverage Centers



Only cosmetic parts available

