

# GAGGENAU



## Controls centered

### Right-hinged

**BX 480 612**

Stainless steel-backed full glass door  
Width 30" (76 cm)

### Left-hinged

**BX 481 612**

Stainless steel-backed full glass door  
Width 30" (76 cm)

## Included accessories

For the upper oven:

- 1 wire rack
- 1 baking tray, pyrolysis-safe enamel
- 1 broil tray with wire rack

For the lower oven:

- 1 plug-in core temperature probe
- 1 rotisserie spit
- 1 wire rack
- 1 enameled pyrolysis-safe baking tray
- 1 broil tray with wire rack

## Optional accessories

**BA 018 165**

Pull-out system  
Fully extendable telescopic rails and enameled cast iron frame.

**BA 028 115**

Baking tray, enameled  
1" deep.

**BA 038 165**

Wire rack, chromium-plated  
Without opening, with feet.

**BA 058 115**

Heating element for baking stone and Gastronorm roaster

**BA 058 133**

Baking stone  
Incl. baking stone support and pizza peel (heating element must be ordered separately). Cannot be used in combination with pull-out system.

**BS 020 002**

Pizza peel, additional set of 2.

**GN 340 230**

Gastronorm roaster in cast aluminum.  
GN 2/3, height 4", with 2 1/2" lid non-stick.

## 400 series double oven

**BX 480/BX 481**

- Pyrolysis system
- 17 heating methods, with rotisserie spit, roaster and baking stone function
- Core temperature probe with estimation of cooking time
- TFT touch display
- Electronic temperature control from 85°F to 550°F
- 2x net volume per cooking compartment 4.5 cu.ft.
- Star-K certified.

## Cooking modes

Convection.  
Economy convection.  
Top + bottom heat.  
Top + 1/2 bottom heat.  
Top heat.  
1/2 top + bottom heat.  
Bottom heat.  
Convection + bottom heat.  
Convection + 1/2 bottom heat.  
Broil + circulated air.  
Broil.  
Economy broil.  
Baking stone function.  
Roaster function.  
Dough proofing.  
Defrosting.  
Keeping warm.

## Operation

Rotary knob and TFT touch display operation.  
Clear text display in 44 languages.  
Information key with use indicators.  
Side-opening door opens up to 180° angle.

## Features

Three-point core temperature probe with automatic shut-off and estimation of cooking time.  
Rotisserie spit (lower oven).  
Outlet for optional additional heating element used for baking stone or gastronorm roaster function.  
Actual temperature display.  
Super-quick preheating.  
Timer functions: cooking time, cooking-time end, timer, stop watch, long-term timer (Sabbath mode).  
60 W halogen light on the top.  
10 W halogen light on the side.  
Enameled side rack supports with 5 rack levels, pyrolysis-safe.

## Safety

Thermally insulated door with quadruple glazing.  
Child lock.  
Safety shut-off.  
Cooled housing with temperature protection.

## Cleaning

Pyrolysis system.  
Gaggenau enamel.  
Heated catalyzer to clean the oven air.

## Planning notes

Door hinge not reversible.  
The front of the appliance extends 1 7/8" from the cabinet front.  
The outer edge of the door handle extends 3 1/16" from the cabinet front  
When planning a corner solution, pay attention to the 90° door opening angle. Consider the overhang, incl. the

door handle, when planning to open drawers next to the appliance.  
Plan a gap of at least 3/16" between the appliance and adjacent cabinets.  
To achieve the 21 9/16" installation depth, the connecting cable needs to follow the slanted edge on the lower right hand corner of the housing.  
Locate electrical box in cabinet above unit.

Please read the installation details regarding air openings on pages 12-13.

## Rating

Total rating: 9.2 kW.  
Total Amps: 40 A.  
208/220-240 V / 60 Hz  
Plan for a 70 7/8" connecting cable (hardwire required).

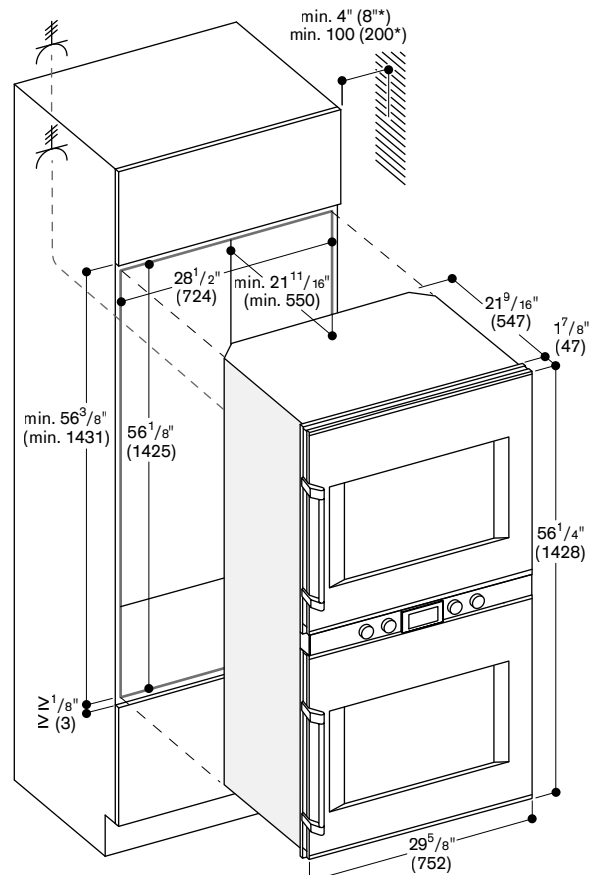

\* 8" (200 mm) in connection with BA 018

Numbers indicated  
inside parenthesis ( ) = mm

www.gaggenau.com

